

## Certificate of Property Use

Issued under the authority of the Environmental Protection Act, R.S.O. 1990, c. E.19,  
sections 168.6 (CPU) and 197 (Order)

Certificate of Property use number 5677-CSBPMY  
Risk Assessment number 7658-B3LPLA

**Owner:** City of Toronto Economic Development Corporation  
61 Front Street West  
Union Station, East Wing, 3<sup>rd</sup> Floor  
Toronto, ON M5J 1E5

**Site:** 312 Cherry Street, Toronto ON

with a legal description as set out below:

PLAN 66R-30543, PART 1

Being Part of PIN 21385-0149 (LT)

**The conditions of this Certificate of Property Use (CPU) address the Risk Management Measures in the Risk Assessment noted above and described in detail in Part 1 below (Risk Assessment). In the event of a conflict between the CPU and the Risk Assessment, the conditions of the CPU take precedence.**

**Summary:**

***Refer to Part 1 of the CPU, Interpretation, for the meaning of all the defined capitalized terms that apply to the CPU.***

- i) CPU requirements addressed in Part 4 of the CPU, Director Requirements, are summarized as follows:
- |  |     |
|--|-----|
| a. Installing/maintaining any equipment                                      | Yes |
| b. Monitoring any contaminant  | Yes |
| c. Refraining from constructing any building specified                       | Yes |
| d. Refraining from using the Property for any use specified                  | Yes |
| e. Other: Maintaining a barrier to site soils and preparing and implementing |     |

a soil and groundwater management plan and health and safety plan for the Property. Yes

- ii) Duration of Risk Management Measures identified in Part 4 of the CPU is summarized as follows:
- a. The barrier to site soils over the entirety of the Property shall be maintained indefinitely until the Director alters or revokes the CPU.
  - b. The soil and groundwater management plan and the health and safety plan shall be required for the Property during any activities potentially in contact with or exposing site soils for as long as the Contaminants of Concern are present on the Property.
  - c. All other Risk Management Measures shall continue indefinitely until the Director alters or revokes the CPU.

## Part 1: Interpretation

In the CPU the following terms shall have the meanings described below:

“Adverse Effect” has the same meaning as in the Act; namely,

- a. impairment of the quality of the natural environment for any use that can be made of it;
- b. injury or damage to property or to plant or animal life;
- c. harm or material discomfort to any person;
- d. an adverse effect on the health of any person;
- e. impairment of the safety of any person;
- f. rendering any property or plant or animal life unfit for human use;
- g. loss of enjoyment of normal use of property; and,
- h. interference with the normal conduct of business.

“Act” means the *Environmental Protection Act*, R.S.O. 1990, c. E. 19.

“Building” means an enclosed structure occupying an area greater than ten square metres consisting of a wall or walls, roof and floor.

“Building Area” means the horizontal area of a Building at Grade within the outside surface of the exterior wall or walls.

“Building Code” means Ontario Regulation 332/12 (Building Code) made under the *Building Code Act, 1992*, S.O. 1992, c.23.

“CBRA” means a community-based risk assessment as described in report entitled “Community Based Risk Assessment, Port Lands, Ontario” prepared by CH2M Hill Canada Hill Limited dated December 2020.

“CBRA Project Area” means that portion of the Port Lands bounded by Saulter Street to the east, Shipping Channel to the south, Lake Ontario to the west and Keating Channel to the north with additional lands in part at 324 Cherry Street and 429, 480 and 520 Lakeshore Boulevard East, with boundaries shown in Figure 1-2 of the CPU in red.

“Contaminant” has the same meaning as in the Act; namely any solid, liquid, gas, odour, heat, sound, vibration, radiation or combination of any of them, resulting directly or indirectly from human activities that causes or may cause an Adverse Effect.

“Contaminants of Concern” has the meaning as set out in section 3.2 of the CPU.

“CPU” means this Certificate of Property Use as may be altered from time to time and bearing the document number 5677-CSBPMY.

"Director" means the undersigned Director, or any other person appointed as a Director for the purpose of issuing a certificate of property use.

“EBR” means the *Environmental Bill of Rights, 1993*, S.O. 1993, c. 28.

“Fill Cap Target Concentrations” means the barrier risk management measure-based concentrations established for the Contaminants of Concern as set out in the Risk Assessment and in Schedule ‘A’ of the CPU.

“Grade” has the same meaning as in the Building Code.

“Licensed Professional Engineer” means a person who holds a licence, limited licence or temporary licence under the Professional Engineers Act, R.S.O. 1990, c. P.28.

“Ministry” means the ministry of the government of Ontario responsible for the administration of the Act, currently named the Ministry of the Environment, Conservation and Parks.

“O. Reg. 153/04” means Ontario Regulation 153/04, “Record of Site Condition – Part XV.1 of the Act” made under the Act.

“O. Reg. 347/90 means Ontario means R.R.O. 1990, Regulation 347 General - Waste Management” made under the Act.

“Owner” means the owner(s) of the Property, beginning with the person(s) to whom the CPU is issued, described in the “Owner” section on Page 1 above, and any subsequent owner(s) of the Property.

"OWRA" means the *Ontario Water Resources Act*, R.S.O. 1990, c.O.40.

“Property” means the property that is the subject of the CPU and described in the “Site” section on page 1 above.

"Property Specific Standards" means the property specific standards established for the Contaminants of Concern set out in the Risk Assessment and in section 3.2 of the CPU and are the same standards specified in the Risk Assessment.

"Provincial Officer" means a person who is designated as a provincial officer for the purposes of the Act.

"Qualified Person" means a person who meets the qualifications prescribed in subsection 5 (2) of O. Reg. 153/04, namely a person who:

- a. Holds a licence, limited licence or temporary licence under the *Professional Engineer Act*, or
- b. Holds a certificate of registration under the *Professional Geoscientists Act, 2000*, and is a practicing member, temporary member, or limited member of the Association of Professional Geoscientists of Ontario.

"Risk Assessment" means the Risk Assessment number 7658-B3LPLA accepted by the Director on May 24, 2023, and set out in the following documents:

- Report entitled "Port Lands Flood Protection and Enabling, Infrastructure Project, 312 Cherry Street, Toronto, Ontario, Risk Assessment of Record of Site Condition Group 1", prepared by Jacobs Engineering Group Inc., dated November 2018;
- Report entitled "Port Lands Flood Protection and Enabling, Infrastructure Project, 312 Cherry Street, Toronto, Ontario, Risk Assessment for Promontory Park North", prepared by Jacobs Engineering Group Inc., dated October 2021;
- Report entitled "Port Lands Flood Protection and Enabling, Infrastructure Project, 312 Cherry Street, Toronto, Ontario, Risk Assessment for Promontory Park North, Risk Assessment 7658-B3LPLA, TASDB File RA1710-18c", prepared by Jacobs Engineering Group Inc., dated January 2023; and
- Email entitled "RE: Risk Assessment for 312 Cherry Street, Toronto; RA1710-18c; IDS# 7658-B3LPLA" prepared by Jacobs Engineering Group Inc., dated May 20, 2023; with following attachment: o Section 7 – Risk Management Plan; file name: \_PPN\_RA1710-18\_Section7\_20230522.pdf.

"Risk Management Measures" means the risk management measures specific to the Property described in the Risk Assessment and/or Part 4 of the CPU.

"Storage Garage" has the same meaning as the Building Code.

"Sub Slab Vapour Venting Layer" means an engineered venting layer and associated Venting Components above the sub-slab materials for building construction and below a Vapour Barrier, as designed by a Licenced Professional Engineer which operates in a passive manner but can be converted into an active system if necessary, providing pressure relief, collection and venting of vapours away from a building.

"Tribunal" has the same meaning as in the Act, namely the Ontario Land Tribunal.

“Unimpacted Fill” means soil that meets the Fill Cap Target Concentrations for soil in Schedule ‘A’ of the CPU, or loose granular material/fill and crushed stone from an Ontario Ministry of Natural Resources and Forestry-licensed quarry.

“Vapour Barrier” means a geo-synthetic barrier (including but not limited to geomembrane or spray applied equivalent) meeting the appropriate gas permeability and chemical resistance specifications to be considered impermeable and resistant to the Contaminants of Concern as per Risk Assessment and is considered appropriate by the Licensed Professional Engineer and Qualified Person for its application.

“Venting Components” means a network of perforated piping/plenums or venting composites embedded in granular materials of sufficient permeability or other venting products with continuous formed void space that convey vapours and direct these vapours into vent risers that terminate above the roof elevation with option of wind-driven turbines to support passive venting, or active venting if required.

## **Part 2: Legal Authority**

- 2.1 Section 19 of the Act states that a certificate of property use is binding on the executor, administrator, administrator with the will annexed, guardian of property or attorney for property of the person to whom it was directed, and on any other successor or assignee of the person to whom it was directed.
- 2.2 Subsection 132(1.1) of the Act states that the Director may include in a certificate of property use a requirement that the person to whom the certificate is issued provide financial assurance to the Crown in right of Ontario for any one or more of,
  - a. the performance of any action specified in the certificate of property use;
  - b. the provision of alternate water supplies to replace those that the Director has reasonable and probable grounds to believe are or are likely to be contaminated or otherwise interfered with by a contaminant on, in or under the property to which the certificate of property use relates; and
  - c. measures appropriate to prevent adverse effects in respect of the property to which the certificate of property use relates.
- 2.3 Section 168.6 (1) of the Act states that if a risk assessment related to the property has been accepted under clause 168.5 (1) (a), the Director may issue a certificate of property use to the owner of the property, requiring the owner to do any of the following things:
  1. Take any action that is specified in the certificate and that, in the Director’s opinion, is necessary to prevent, eliminate or ameliorate any adverse effect that has been identified in the risk assessment, including installing any equipment, monitoring any contaminant or recording or reporting information for that purpose.
  2. Refrain from using the property for any use specified in the certificate or from constructing any building specified in the certificate on the property.
- 2.4 Subsection 168.6(2) of the Act states that a certificate of property use shall not require

- an owner of property to take any action that would have the effect of reducing the concentration of a contaminant on, in or under the property to a level below the level that is required to meet the standards specified for the contaminant in the risk assessment.
- 2.5 Subsection 168.6(3) of the Act states that the Director may, on his or her own initiative or on application by the owner of the property in respect of which a certificate has been issued under subsection 168.6(1),
- a. alter any terms and conditions in the certificate or impose new terms and conditions; or
  - b. revoke the certificate.
- 2.6 Subsection 168.6(4) of the Act states that if a certificate of property use contains a provision requiring the owner of property to refrain from using the property for a specified use or from constructing a specified building on the property,
- a. the owner of the property shall ensure that a copy of the provision is given to every occupant of the property;
  - b. the provision applies, with necessary modifications, to every occupant of the property who receives a copy of the provision; and
  - c. the owner of the property shall ensure that every occupant of the property complies with the provision.
- 2.7 Subsection 197(1) of the Act states that a person who has authority under the Act to make an order or decision affecting real property also has authority to make an order requiring any person with an interest in the property, before dealing with the property in any way, to give a copy of the order or decision affecting the property to every person who will acquire an interest in the property as a result of the dealing.
- 2.8 Subsection 197(2) of the Act states that a certificate setting out a requirement imposed under subsection 197(1) may be registered in the proper land registry office on the title of the real property to which the requirement relates, if the certificate is in a form approved by the Minister, is signed or authorized by a person who has authority to make orders imposing requirements under subsection 197(1) and is accompanied by a registrable description of the property.
- 2.9 Subsection 197(3) of the Act states that a requirement, imposed under subsection 197(1) that is set out in a certificate registered under subsection 197(2) is, from the time of registration, deemed to be directed to each person who subsequently acquires an interest in the real property.
- 2.10 Subsection 197(4) of the Act states that a dealing with real property by a person who is subject to a requirement imposed under subsection 197(1) or 197(3) is voidable at the instance of a person who was not given the copy of the order or decision in accordance with the requirement.

## Part 3: Background

- 3.1 The Risk Assessment was undertaken for the Property on behalf of the Owner to assess the human health risks and ecological risks associated with the presence or discharge of Contaminants on, in or under the Property and to identify appropriate Risk Management Measures to be implemented to ensure that the Property is suitable for the intended use: “parkland use”, as defined in O. Reg. 153/04.
- 3.2 The Contaminants on, in or under the Property that are present above the Residential/Parkland/Institutional Property Use Standards within **Table 9** (and **Table 7** for volatiles in groundwater) of the **Soil, Ground water and Sediment Standards for Use under Part XV.1 of the Act** for coarse textured soils published by the Ministry and dated April 15, 2011, for which there are no such standards are defined as the Contaminants of Concern. The Property Specific Standards and the fill cap target concentration for soil for the Contaminants of Concern are set out in Schedule ‘A’; the soil vapour and indoor air trigger levels are set out in Schedule ‘B’; the sub slab monitoring and indoor air sampling requirements are set out in Schedules ‘C’ and ‘D’ as attached to and forming part of the CPU with the following figures:
- Plan of Survey (66R-30543) with the Property shaded in red; and
  - Figures I-1 to I-7, I-9 to I-11 and 1-2.
- 3.3 I am of the opinion, for the reasons set out in the Risk Assessment that the Risk Management Measures described therein and outlined in Part 4 of the CPU are necessary to prevent, eliminate or ameliorate an Adverse Effect on the Property.

## Part 4: Director’s Requirements

Pursuant to the authority vested in me under section 168.6(1) of the Act, I hereby require the owner to do or cause to be done the following:

- 4.1 Implement, and thereafter maintain or cause to be maintained, the Risk Management Measures.
- 4.2 Without restricting the generality of the foregoing in Item 4.1, carry out or cause to be carried out the following key elements of the Risk Management Measures:
- a. Refrain from planting any plants or produce that are edible or intended for human consumption unless grown in self-contained in above Grade planter boxes or beds having no contact with soils on Property.
  - b. The Property shall be covered by a barrier to site soils designed, installed and maintained in accordance with the Risk Assessment so as to prevent exposure to the Contaminants of Concern. The barrier to site soils shall consist of a hard cap, fill/soil cap and/or fence as specified below:
    - i. Hard caps on the Property shall have a minimum total thickness of 1500 mm consisting of asphalt, concrete, armour stone, bedding granular, compacted

- granular, cobbles, crushed concrete, unshrinkable fill, grates, pavers, paving stones, rubberized surfaces underlain by Unimpacted Fill (as illustrated by figure I-1 of the CPU).
- ii. Hard caps on the Property that cannot be fully excavated to 1500 mm due to geotechnical or structural restrictions as per Risk Assessment shall have a minimum thickness of 225 mm consisting of asphalt, concrete, armour stone, bedding granular, compacted granular, cobbles, unshrinkable fill, grates, pavers, paving stones, rubberized surfaces underlain by Unimpacted Fill and these locations shall be identified and managed within the health and safety plan as per Item 4.2 e. of the CPU.
  - iii. Fill caps on the Property shall consist of a minimum thickness of 1500 mm consisting of Unimpacted Fill (as illustrated by figure I-2 of the CPU).
  - iv. Fill caps on the Property that cannot be fully excavated to 1500 mm due to geotechnical or structural restrictions as per Risk Assessment shall have a minimum thickness of 500 mm consisting of Unimpacted Fill and these locations shall be identified and managed within the health and safety plan as per Item 4.2 e. of the CPU.
  - v. Interim caps may be applied on a temporary basis only during the redevelopment and no more than five (5) years and shall have a minimum thickness of 50 mm consisting of only asphalt and/or concrete underlain by a subbase granular fill layer of 100 mm in minimum thickness, or a minimum thickness of 100 mm consisting of only granular fill or a minimum thickness of 300 mm consisting of Unimpacted Fill (as illustrated by figure I-3 of the CPU).
  - vi. Utility trenches or corridors containing utility pipes within a fill cap must include at least a 500 mm fill cap below the utility consisting of Unimpacted Fill (as illustrated by figure I-4).
  - vii. Utility trenches or corridors containing utility pipes below a fill cap and with a utility pipe diameter less than 900 mm on the Property shall consist of Unimpacted Fill to the top of the utility pipe, a minimum thickness of 600 mm on either side of the utility pipe and a minimum thickness of 500 mm below the utility pipe (as illustrated by figure I-4 of the CPU).
  - viii. Utility trenches or corridors containing utility pipes below a fill cap and with a utility pipe diameter more than 900 mm on the Property shall consist of Unimpacted Fill to the top of the utility pipe, a minimum thickness of 1300 mm on either side of the utility pipe and a minimum thickness of 500 mm below the utility pipe (as illustrated in figure I-4 of the CPU).
  - ix. For portion(s) of the Property, not under development or not in use and does not have an interim cap shall have a fence barrier to prevent the general public from accessing the site and a dust control plan to prevent surface soil from impacting the adjacent properties.
- c. An inspection and maintenance program shall be prepared and implemented to ensure the continuing integrity of the barriers to site soils risk management measures (including any building foundations, interim barriers and fence barrier) as long as the Contaminants of Concern are present on the Property. The inspection program shall include, at a minimum, every month for an interim granular barrier (100 mm thickness) and semi-annual (every six months) inspections for all other barrier to site soils. Any barrier to site soils deficiencies shall be repaired forthwith. Inspection, deficiencies and repairs shall be recorded in a logbook maintained by the Owner and made available upon request by a Provincial Officer.



- d. A soil and groundwater management plan shall be prepared for the Property and implemented during any activities potentially coming in contact with or exposing site soils or groundwater. A copy of the plan shall be kept by the Owner and made available for review by a Provincial Officer upon request. Implementation of the plan shall be overseen by a Qualified Person and shall include, but not be limited to, provisions for soils excavation, stockpiling, characterization, disposal and record keeping specified below:
- i. Dust control measures and prevention of soil tracking by vehicles and personnel from the Property, which may include wetting of soil with potable water, reduced speeds for on-site vehicles, tire washing stations and restricting working in high wind conditions, as required;
  - ii. Management of excavated materials which may include cleaning equipment, placement of materials for stockpiling on designated areas lined and covered with polyethylene sheeting, bermed and fenced to prevent access, runoff control to minimize contact and provisions for discharge to sanitary sewers or other approved treatment, as required;
  - iii. Characterization of excavated soils to determine if soils exceed the Property Specific Standards shall follow the soil sampling strategy in the Risk Assessment. Excavated soils and materials requiring off-site disposal as a waste shall be disposed of in accordance with the provisions of O. Reg. 347/90, as amended, made under the Act. Excavated soils meeting the Property Specific Standards may be placed below the barrier to site soils if deemed suitable by a Qualified Person and in accordance with the Risk Assessment. Excavated soils meeting the Fill Cap Target Concentrations in Schedule 'A' of the CPU may be placed within the barrier to site soils if deemed suitable by a Qualified Person and in accordance with the Risk Assessment.
  - iv. Soils brought to the Property shall follow the soil sampling strategy in the Risk Assessment including any leachate testing as per Risk Assessment and only soils meeting the Fill Cap Target Concentrations in Schedule 'A' of the CPU may be placed within the barrier to site soils if deemed suitable by a Qualified Person and in accordance with the Risk Assessment.
  - v. Soils originating from within the CBRA Project Area brought to the Property shall follow the soil sampling strategy including any leachate testing as per the Risk Assessment and only soils meeting the controlled fill target concentrations per table 7-2b of the Risk Assessment for placement below risk management measures if deemed suitable by a Qualified Person and in accordance with the Risk Assessment.
  - vi. Soils brought to the Property from outside of the CBRA Project Area shall follow the soil sampling strategy including any leachate testing in the Risk Assessment and only soils meeting the residential/parkland/institutional property use standards within Table 9 of the Soil, Ground Water and Sediment Standards for Use under Part XV.1 of the Act for coarse textured soils published by the Ministry and dated April 15, 2011, is to be placed on, in or under the Property.
  - vii. Record keeping including dates and duration of work, weather and site conditions, location and depth of excavation activities, dust and odour control measures, stockpile management and drainage, soil characterization results, names of the Qualified Person, contractors, haulers and receiving sites for any soil or contaminated ground water removed from the Property and any complaints received relating to site activities potentially coming in contact with

or exposing site soils and ground water.

- e. A site-specific health and safety plan shall be developed for the Property and implemented during all intrusive, below-grade construction activities potentially coming in contact with or exposing site soils or groundwater and a copy shall be maintained on the Property for the duration of these intrusive activities. The Owner shall ensure that the health and safety plan take into account the presence of the Contaminants of Concern and including methane and is implemented prior to any intrusive work being done on the Property in order to protect workers from exposure to the Contaminants of Concern and methane. The health and safety plan shall be prepared in accordance with applicable Ministry of Labour health and safety regulations, shall address any potential risks identified in the Risk Assessment, and shall include, but not be limited to,
  - i. Methane monitoring and management safe work procedures as described in Risk Assessment;
  - ii. occupational hygiene requirements;
  - iii. requirements for personal protective equipment for direct contact, soil vapours and methane, and
  - iv. contingency plan requirements including site contact information.

Prior to initiation of any project (as defined in the Occupational Health and Safety Act, as amended) on the Property, the local Ministry of Labour office shall be notified of the proposed activities and that the Property contains contaminated soil, groundwater and methane. Implementation of the health and safety plan shall be overseen by persons appropriately qualified to review the provisions of the plan with respect to the proposed site work and conduct daily inspections. The Owner shall retain a copy of the plan, which shall be made available for review by a Provincial Officer upon request.

- f. Refrain from constructing any Building on, in or under the Property unless the Building contains a vapour mitigation system and is slab on Grade as follows:
  - i. All Building(s) on the Property include the sealing of foundation penetrations and sumps, a Vapour Barrier, Sub Slab Vapour Venting Layer and Venting Components as described in the Risk Assessment (and as illustrated in figures I-5, I-6, I-7, I-9, and I-10 of the CPU).
  - ii. The Owner shall retain a copy of all Vapour Barrier, Sub Slab Vapour Venting Layer and Venting Component as-built drawings signed by a Licensed Professional Engineer along with the proposed testing and performance requirements for the Vapour Barrier, Sub Slab Vapour Venting Layer and Venting Component for inspection by a Provincial Officer.
  - iii. An inspection and maintenance program shall be prepared and implemented to ensure the continuing integrity of the vapour mitigation system. A final inspection for cracks, holes or penetrations in the below grade walls and floors shall be conducted before any finishes are applied to the walls and floors and prior to occupancy and shall be recorded in a logbook. Any holes, cracks or penetrations shall be repaired and sealed immediately and recorded in a logbook.
  - iv. With regard to the venting layer and Venting Components, inspections of the venting layer and Venting Components, where visually accessible, will be made for potential breaches. The inspection program shall include semi-

annual (every six months) inspections as per the Risk Assessment and any deficiencies shall be repaired forthwith. The inspection results shall be recorded in a log book maintained by the Owner and available upon request by a Provincial Officer.

- g. Refrain from constructing any Building on, in or under the Property other than a Building that meets the requirements of Item 4.2 f. of the CPU unless the Building contains a Storage Garage, as defined in Building Code, and meets the following requirements:
  - i. the Storage Garage is constructed at or below the Grade of the Building and the sealing of all sumps and penetrations into the Building;
  - ii. The Storage Garage area covers the entire area of the Building footprint at the final Grade of the Building;
  - iii. The Storage Garage is in compliance with all applicable requirements of the Building Code, including, without limitation, the provisions governing the following:
    - 1. design of the mechanical ventilation system as set out in Division B, subsection 6.2.2.3, Ventilation of Storage and Repair Garages;
    - 2. interconnection of air duct systems as set out in Division B, subsection 6.2.3.9 (2); and,
    - 3. air leakage as set out in Division B, section 5.4.
  - iv. The mechanical ventilation system for the Storage Garage is designed to provide, during operating hours a continuous supply of outdoor air at a rate of not less than 3.9 litres per second for each square metre of floor area.
  
- h. Refrain from constructing any Building on, in or under the Property other than a Building that meets the requirements of Item 4.2 f. or 4.2 g. of the CPU unless the Building is intended for use as storage shed and is a slab on Grade with no vertical below-Grade foundation walls as follows:
  - i. All Building(s) on the Property include the sealing of foundation penetrations and sumps, a Vapour Barrier, with moisture and waterproofing as described in the Risk Assessment.
  - ii. The Owner shall retain a copy of all Vapour Barrier as-built drawings signed by a Licensed Professional Engineer along with the proposed testing and performance requirements for the Vapour Barrier for inspection by a Provincial Officer.
  - iii. An inspection and maintenance program shall be prepared and implemented to ensure the continuing integrity of the Vapour Barrier. A final inspection for cracks, holes or penetrations in the below grade walls and floors shall be conducted before any finishes are applied to the walls and floors and prior to occupancy and shall be recorded in a logbook. Any holes, cracks or penetrations shall be repaired and sealed immediately and recorded in a logbook.
  - iv. The inspection program shall include semi-annual (every six months) inspections as per the Risk Assessment and any deficiencies shall be repaired forthwith. The inspection results shall be recorded in a logbook maintained by the Owner and available upon request by a Provincial Officer.
  
- i. Refrain from constructing any temporary Building on, in under the Property other than a temporary Building that contains a vapour mitigation system and is in use and

standing less than 12 consecutive months as follows:

- i. All temporary Building(s) on the Property shall include a Vapour Barrier or hard cap surfaces that are sealed, and a passive venting system through an open space below the raised temporary flooring or through a well-ventilated tent space as described in the Risk Assessment (and as Illustrated in figure I-11).
  - ii. The Owner shall retain a copy of all Vapour Barrier and open space as-built drawings signed by a Licensed Professional Engineer along with the proposed testing and performance requirements for the Vapour Barrier for inspection by a Provincial Officer.
  - iii. An inspection and maintenance program shall be prepared and implemented to ensure the continuing integrity of the Vapour Barrier and open space or tent. A final inspection for cracks, holes or penetrations in the below grade walls and floors shall be conducted before any finishes are applied to the walls and floors and prior to occupancy and shall be recorded in a logbook. Any holes, cracks or penetrations shall be repaired and sealed immediately and recorded in a logbook.
  - iv. The inspection program shall include semi-annual (every six months) inspections as per the Risk Assessment and any deficiencies shall be repaired forthwith. The inspection results shall be recorded in a logbook maintained by the Owner and available upon request by a Provincial Officer.
- j. The air monitoring requirements on the Property is to commence prior to occupancy of any Building on the Property. All air monitoring programs shall be done in accordance with USEPA Method TO-15 for the Contaminants of Concerns listed in Schedule 'B' of the CPU except for mercury shall be done in accordance to NIOSH 6009 using sorbent tube and all indoor air monitoring with summa canisters shall be done using a 24-hour regulator (sample duration). The air monitoring program shall be carried out as follows:
- i. For any Building(s) that meets the requirements of 4.2 g. or 4.2 h. or 4.2 i. of the CPU; the indoor air or sub slab soil vapour monitoring shall be carried out as a one-time monitoring event prior to occupancy.
  - ii. For all other Building(s), the indoor air or sub slab soil vapour monitoring shall commence prior to occupancy and carried out on a quarterly basis (every three months) for the first year, and tri-annually (every four months) for the second year and thereafter until such time as Director, upon application by the Owner, has reviewed the data available and either alters or revokes the CPU.
  - iii. All air monitoring and sampling shall be done in accordance with the Ministry's document entitled "(Draft) Technical Guidance for Soil Vapour Intrusion Assessment" dated January 4, 2021, and any outdoor air sampling shall be done in accordance with The Ministry's "Operations Manual for Air Quality Monitoring in Ontario", dated January 2018 for the Contaminants of Concerns listed in Schedule 'B'.
  - iv. Sampling locations for the soil vapour probes or for indoor air shall be identified by an appropriately qualified person to be protective of human health for any persons using or occupying the buildings on the Property. The minimum number of indoor air or sub slab vapour samples per Building Area shall follow Schedule 'C' for sub slab soil vapour monitoring or Schedule 'D' for indoor air monitoring.
  - v. If the air concentration for any Contaminants of Concern exceeds Schedule

- 'B' for any trigger level, the Owner shall immediately notify the Director in writing of the exceedance along with a copy of the soil vapour probe construction logs, laboratory's certificate of analysis and chain of custody, field notes indicating the initial and final canister pressures, atmospheric pressure, weather and temperature.
- vi. The Owner shall keep a copy of all sampling data and records available for inspection by a Provincial Officer upon request.
  - vii. If the air concentration for the Contaminants of Concern exceeds Schedule 'B' for any trigger level, then indoor air or sub slab soil vapour monitoring shall recommence for all Contaminants of Concern within fifteen (15) days of receipt of the analytical results and be carried out as follows:
    - 1. If none of the concentrations of the Contaminants of Concern exceed Schedule 'B' (trigger levels) on the recommenced indoor air or sub slab soil vapour monitoring event, then the indoor air or sub slab soil vapour monitoring event shall be carried out on a quarterly basis (every three months) for a twelve (12) month period (4 additional monitoring events).
    - 2. If any of the concentrations of the Contaminants of Concern exceeds Schedule 'B' (trigger levels), on the recommenced indoor air or sub slab vapour monitoring event, then a Licenced Professional Engineer shall, within 30 days of the receipt of the analytical results, either
      - i. develop and submit a detailed contingency plan (as outlined in Risk Assessment) to address the soil vapours in the Building to the Director; or
      - ii. develop and submit a report to the Director that details these indoor air exceedances are due to background sources.
 The air monitoring shall continue on a quarterly basis (every 3 months) until such time as the Director, upon application by the Owner, has reviewed the data available and either alters or revokes the CPU.
  - k. The Owner shall retain a copy of the site plan prepared and signed by a Qualified Person prior to occupancy which will describe the Property, placement and quality of all the barriers to site soils. The site plan will include a plan and cross section drawings specifying the vertical and lateral extent of the barriers. This site plan shall be retained by the Owner for inspection upon request by a Provincial Officer. The site plan shall be revised following the completion of any alteration to the extent of the barriers to site soils.
  - l. The Owner shall prepare by March 31 each year, an annual report documenting activities relating to the Risk Management Measures undertaken during the previous calendar year. A copy of this report shall be maintained on file by the Owner and shall be made available upon request by a Provincial Officer. The report shall include, but not be limited to, the following minimum information requirements:
    - i. a copy of all records related to the inspection and maintenance program for the barrier to site soils, and vapour mitigation systems and Vapour Barriers;
    - ii. a copy of all records related to the soil and groundwater management plan and the health and safety plan on the Property;
    - iii. a copy of all records for air monitoring including soil vapour probe construction logs, laboratory's certificate of analyses and chain of custody, and field notes indicating the initial and final canister pressures, atmospheric pressure, weather and temperature;

- iv. a copy of all as-builts for vapour mitigation systems and Vapour Barriers;
  - v. a copy of all signed site plans including any alterations.
  - vi. a copy of the updated financial assurance every five years from the date of issuance of the CPU if applicable.
- 4.3 Refrain from using the Property for any of the following use(s): all property uses except for following uses as defined in O.Reg. 153/04: “parkland use”.
- 4.4 Refrain from constructing the following building(s): No building construction unless construction is in accordance with Items 4.2 f., 4.2 g., 4.2 h. or 4.2 i. of the CPU.
- 4.5 The Owner shall ensure that every occupant of the Property, with the exception of recipients of recreational park permits, is given notice that the Ministry has issued this CPU and that it contains the provisions noted above in Items 4.3 and 4.4, unless noted N/A. For the purposes of this requirement, an occupant means any person with whom the Owner has a contractual relationship regarding the occupancy of all or part of the Property.

### Site Changes

- 4.6 In the event of a change in the physical site conditions or receptor characteristics at the Property that may affect the Risk Management Measures and/or any underlying basis for the Risk Management Measures, forthwith notify the Director of such changes and the steps taken, to implement, maintain and operate any further Risk Management Measures as are necessary to prevent, eliminate or ameliorate any Adverse Effect that will result from the presence on, in or under the Property or the discharge of any Contaminant of Concern into the natural environment from the Property. An amendment to the CPU will be issued to address the changes set out in the notice received and any further changes that the Director considers necessary in the circumstances.

### Reports

- 4.7 Retain a copy of any reports required under the CPU, the Risk Assessment and any reports referred to in the Risk Assessment (until otherwise notified by the Director) and within ten (10) days of the Director or a Provincial Officer making a request for a report, provide a copy to the Director or Provincial Officer.

### Property Requirement

- 4.8 For the reasons set out in the CPU and pursuant to the authority vested in me under subsection 197(1) of the Act, I hereby order you and any other person with an interest in the Property, before dealing with the Property in any way, to give a copy of the CPU, including any amendments thereto, to every person who will acquire an interest in the Property as a result of the dealing.

### Certificate of Requirement

- 4.9 Within fifteen (15) days from the date of receipt of a certificate of requirement issued

under subsection 197(2) of the Act and as set out in Schedule 'E', register the certificate of requirement on title to the Property, in the appropriate land registry office.

- 4.10 Immediately after registration of the certificate of requirement, provide to the Director written verification that the certificate of requirement has been registered on title to the Property.

### Owner Change

- 4.11 While the CPU is in effect, the Owner shall forthwith report in writing, to the Director any changes of ownership of the Property, except that while the Property is registered under the Condominium Act, 1998, S.O.1998 c.19, no notice shall be given of changes in the ownership of individual condominium units or any appurtenant common elements on the Property.

### Financial Assurance

- 4.12 Financial Assurance is not required as long as the Owner of the Property is the City of Toronto Economic Development Corporation or the City of Toronto.
- 4.13 If the Owner of the Property is not City of Toronto Economic Development Corporation or City of Toronto, then financial assurance shall be provided to the to the Crown in right of Ontario within fifteen (15) days from the date of transfer of the Property in the amount of one hundred and thirty-two thousand and eight hundred and forty dollars (\$132,840) in a form satisfactory to the Director and in accordance with Part XII of the Act.
- 4.14 A written report reviewing the financial assurance required by the CPU shall be included in the annual report referred to as Item 4.2 n. with an updated cost estimate with respect to the matters dealt with in Item 4.13 above.

## **Part 5: General**

- 5.1 The requirements of the CPU are severable. If any requirement of the CPU or the application of any requirement to any circumstance is held invalid, such finding does not invalidate or render unenforceable the requirement in other circumstances nor does it invalidate or render unenforceable the other requirements of the CPU.
- 5.2 An application under sub section 168.6(3) of the Act to,  
a. alter any terms and conditions in the CPU or impose new terms and conditions; or  
b. revoke the CPU;  
shall be made in writing to the Director, with reasons for the request.
- 5.3 The Director may alter the CPU under subsections 132(2) or (3) of the Act to change a requirement as to financial assurance, including that the financial assurance may be

increased or reduced or released in stages. The total financial assurance required may be reduced from time to time or released by an order issued by the Director under section 134 of the Act upon request and submission of such supporting documentation as required by the Director.

- 5.4 Subsection 186(3) of the Act provides that failure to comply with the requirements of the CPU constitutes an offence.
- 5.5 The requirements of the CPU are minimum requirements only and do not relieve the Owner from,
  - a. complying with any other applicable order, statute, regulation, municipal, provincial or federal law; or
  - b. obtaining any approvals or consents not specified in the CPU.
- 5.6 Notwithstanding the issuance of the CPU, further requirements may be imposed in accordance with legislation as circumstances require. The Director shall also alter the CPU where the approval or acceptance of the Director is required in respect of a matter under the CPU and the Director either does not grant the approval or acceptance or does not grant it in a manner agreed to by the Owner.
- 5.7 In the event that, any person is, in the opinion of the Director, rendered unable to comply with any requirements in the CPU because of,
  - a. natural phenomena of an inevitable or irresistible nature, or insurrections,
  - b. strikes, lockouts or other labour disturbances,
  - c. inability to obtain materials or equipment for reasons beyond your control, or
  - d. any other cause whether similar to or different from the foregoing beyond your control, the requirements shall be adjusted in a manner defined by the Director. To obtain such an adjustment, the Director must be notified immediately of any of the above occurrences, providing details that demonstrate that no practical alternatives are feasible in order to meet the requirements in question.
- 5.8 Failure to comply with a requirement of the CPU by the date specified does not absolve the Owner from compliance with the requirement. The obligation to complete the requirement shall continue each day thereafter.
- 5.9 In the event that the Owner complies with the provisions of Items 4.9 and 4.10 of the CPU regarding the registration of the certificate of requirement on title to the Property, and then creates a condominium corporation by the registration of a declaration and description with respect to the Property pursuant to the Condominium Act, 1998, S.O. 1998, c.19, as amended, and then transfers ownership of the Property to various condominium unit owners, the ongoing obligations of the Owner under this CPU can be carried out by the condominium corporation on behalf of the new Owners of the Property



## Part 6: Information regarding a Hearing before the Ontario Land Tribunal

- 6.1 Pursuant to section 139 of the Act, you may require a hearing before the Ontario Land Tribunal (the “Tribunal”), if within fifteen (15) days after service on you of a copy of the CPU, you serve written notice upon the Director and the Tribunal.
- 6.2 Pursuant to section 142 of the Act, the notice requiring the hearing must include a statement of the portions of the CPU and the grounds on which you intend to rely at the hearing. Except by leave of the Tribunal, you are not entitled to appeal a portion of the CPU, or to rely on a ground, that is not stated in the notice requiring the hearing.
- 6.3 Service of a notice requiring a hearing must be carried out in a manner set out in section 182 of the Act and Ontario Regulation 227/07: *Service of Documents*, made under the Act. The address, email address and fax numbers of the Director and the Tribunal are:

Registrar Ontario Land Tribunal  
655 Bay Street, Suite 1500  
Toronto, ON, M5G 1E5  
Email: OLT.Registrar@ontario.ca

and

Jimena Caicedo  
Ministry of the Environment, Conservation and Parks  
5775 Yonge Street, 8<sup>th</sup> Floor  
Toronto, Ontario  
M2M 4J1  
Fax: 416-326-5536  
Email: Environment.Toronto@ontario.ca

- 6.4 Unless stayed by the Tribunal under section 143 of the Act, the CPU is effective from the date of issue.
- 6.5 If you commence an appeal before the Tribunal, under section 47 of the Environmental Bill of Rights, 1993 (the “EBR”), you must give notice to the public in the EBR registry. The notice must include a brief description of the CPU (sufficient to identify it) and a brief description of the grounds of appeal.

The notice must be delivered to the Environmental Commissioner of Ontario who will place it on the EBR registry. The notice must be delivered to the Environmental Commissioner at 605-1075 Bay Street, Toronto, Ontario M5S 2B1 by the earlier of:

- 6.5.1 two (2) days after the day on which the appeal before the Tribunal was commenced; and

- 6.5.2 fifteen (15) days after service on you of a copy of the CPU.
- 6.6 Pursuant to subsection 47(7) of the EBR, the Tribunal may permit any person to participate in the appeal, as a party or otherwise, in order to provide fair and adequate representation of the private and public interests, including governmental interests, involved in the appeal.
- 6.7 For your information, under section 38 of the EBR, any person resident in Ontario with an interest in the CPU may seek leave to appeal the CPU. Under section 40 of the EBR, the application for leave to appeal must be made to the Tribunal by the earlier of:
- 6.7.1 fifteen (15) days after the day on which notice of the issuance of the CPU is given in the EBR registry; and
- 6.7.2 if you appeal, fifteen (15) days after the day on which your notice of appeal is given in the EBR registry.
- 6.8 The procedures and other information provided in this Part 6 are intended as a guide. The legislation should be consulted for additional details and accurate reference. Further information can be obtained from e-Laws at [www.ontario.ca/laws](http://www.ontario.ca/laws).

Issued at Toronto this 6th day of December 2023

***“Originally Signed by”***

Jimena Caicedo  
Director, section 168.6 of the Act

## Schedule 'A'

### Property Specific Standards (Soil) and Fill Cap Target Concentration for each Contaminant of Concern

Contaminants of Concern (COC)	Property Specific Standards for Soil (µg/g)	Fill Cap Target Concentration for Soil (µg/g)	Property Specific Standards for Groundwater (µg/L)
Acenaphthene	34	0.072	NA
Acenaphthylene	2.5	0.093	NA
Acetone	0.63	0.5	NA
Anthracene	130	0.22	NA
Antimony	14	1.3	NA
Arsenic	220	18	NA
Barium	280	220	NA
Benz(a)anthracene	240	0.036	NA
Benzene	0.56	0.02	NA
Benzo(a)pyrene	180	0.3	NA
Benzo(b&j)fluoranthene	190	0.47	NA
Benzo(g,h,i)perylene	81	0.68	0.44
Benzo(k)fluoranthene	87	0.48	NA
Boron (HWS)	2.6	1.5	NA
Cadmium	2.3	1.2	NA
Chromium	170	70	NA
Chromium Hexavalent	2.5	0.66	NA
Chrysene	200	2.8	NA
Cobalt	85	22	NA
Conductivity (mS/cm)	3.1	0.7	NA
Copper	610	92	NA
Dibenzo[a,h]anthracene	27	0.1	NA
Ethylbenzene	1.2	0.05	NA
Fluoranthene	430	0.69	NA
Fluorene	39	0.19	NA
Indeno[1 2 3-cd]pyrene	80	0.23	0.4
Lead	800	120	NA
Mercury	1.0	0.27	NA
Methylnaphthalenes, 1+2-	26	0.59	NA
Molybdenum	15	2	NA
Naphthalene	13	0.09	NA
n-hexane	0.71	0.05	NA
Nickel	110	82	NA
PHC F1	200	25	NA
PHC F2	1500	10	NA
PHC F3	13,000	240	NA
PHC F4	3300	120	NA
Phenanthrene	430	0.69	NA
Pyrene	460	1.0	NA
Selenium	6.7	1.5	NA
Silver	1.6	0.5	NA
Toluene	2.5	0.2	NA
Trichloroethylene	0.23	0.05	NA
Xylenes, total	4.4	0.05	NA
Zinc	740	290	NA

### Schedule 'B'

#### Air Trigger Levels

Contaminants of Concern (COC)	Soil Vapour Trigger Levels ( $\mu\text{g}/\text{m}^3$ )	Indoor Air Target Levels ( $\mu\text{g}/\text{m}^3$ )
Benzene	25	0.51
Mercury	0.31	0.0063
Naphthalene	39	0.77
PHC F1	13,000	270
PHC F2	4,800	100
Trichloroethylene	14	0.27

### Schedule 'C'

#### Sub Slab Soil Vapour Minimum Samples

Building Area ( $\text{m}^2$ )	Density over Building Area	Minimum Number of Samples
Up to 500	One per 100 $\text{m}^2$	3
>500 to 2000	One additional sample per every 500 $\text{m}^2$ over 500 $\text{m}^2$	5
>2000 to 5000	One additional sample per every 1000 $\text{m}^2$ over 2000	8
>5000	One additional sample per every 2000 $\text{m}^2$ over 5000	11

**Schedule 'D'**

**Indoor Air Minimum Samples**

<b>Building Area (m<sup>2</sup>)</b>	<b>Minimum Number of Samples</b>
Up to 500	2
>500 to 1000	3
>1000	One additional sample per every 1000 m <sup>2</sup> over 1000

**Schedule 'E'**

**CERTIFICATE OF REQUIREMENT**

**s.197(2)**

***Environmental Protection Act***

This is to certify that pursuant to Item 4.9 of Certificate of Property Use number 5677-CSBPMY issued by Jimena Caicedo, Director of the Ministry of the Environment, Conservation and Parks, under sections 168.6 and 197 of the Environmental Protection Act, on December 6, 2023, being a Certificate of Property Use and order under subsection 197(1) of the Environmental Protection Act relating to the Property municipally known as 312 Cherry Street, Toronto being part of Property Identifier PIN 21385-0149 (LT), namely part 1 on Plan 66R-30543 (the "Property") with respect to a Risk Assessment and certain Risk Management Measures and other preventive measure requirements on the Property

**CITY OF TORONTO ECONOMIC DEVELOPMENT CORPORATION**

and any other persons having an interest in the Property, are required before dealing with the Property in any way, to give a copy of the Certificate of Property Use, including any amendments thereto, to every person who will acquire an interest in the Property.

Under subsection 197(3) of the Environmental Protection Act, the requirement applies to each person who, subsequent to the registration of this certificate, acquires an interest in the Property.



Figure I-1

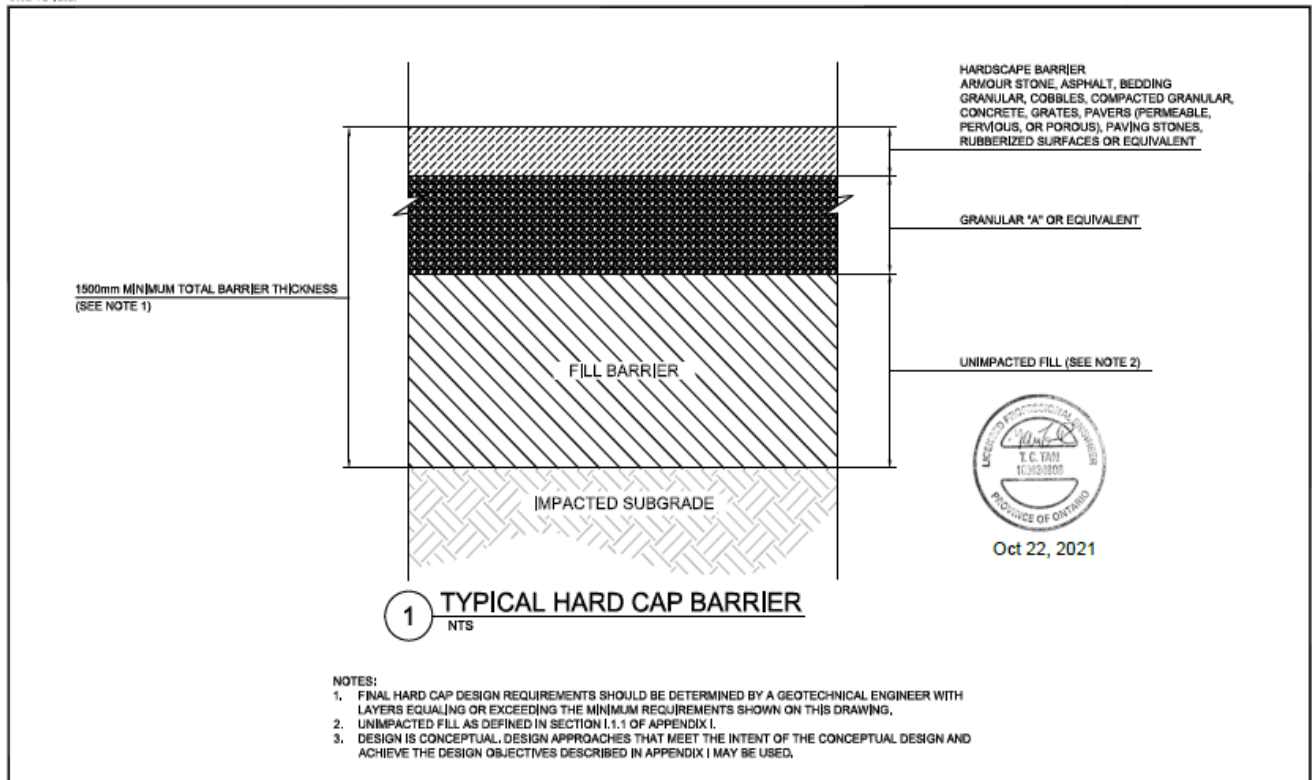
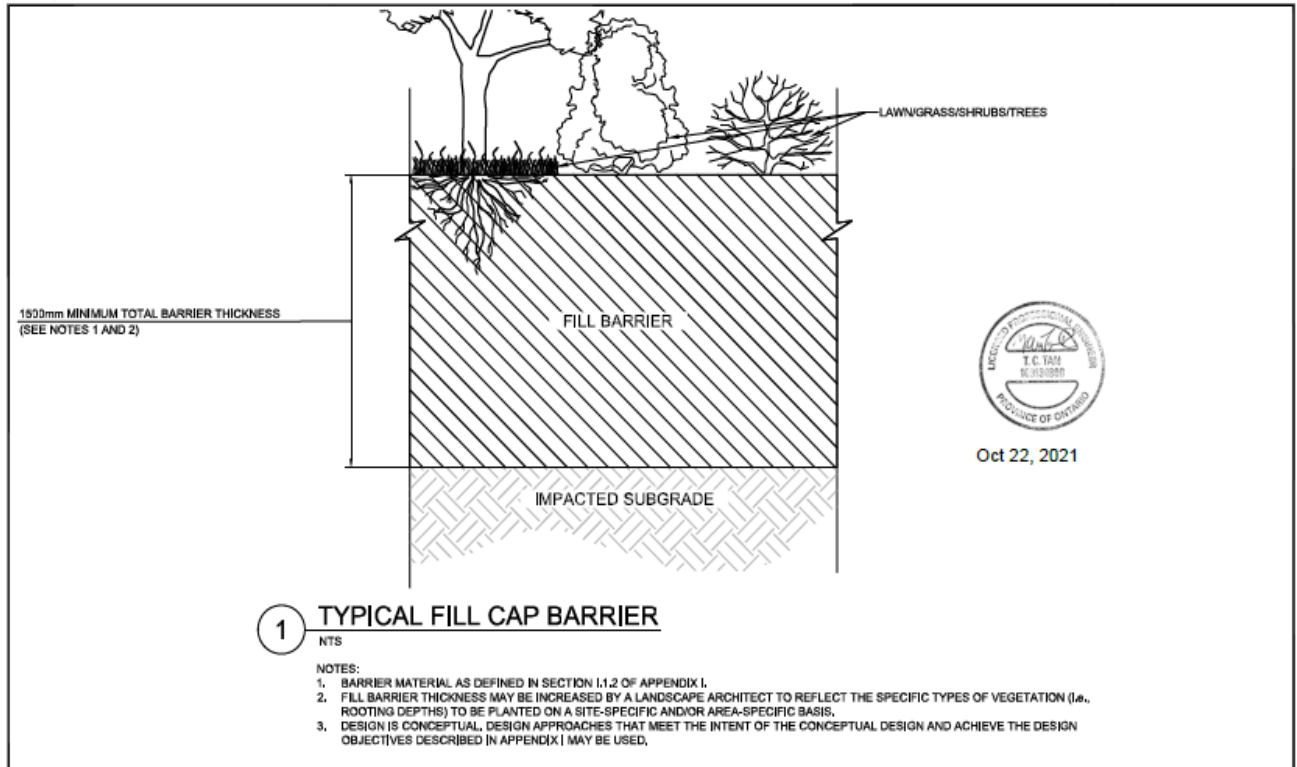

**FIGURE I-1**  
Conceptual Design of Typical Hard Cap Barrier  
(City Parks)

Promontory Park North,  
Toronto, Ontario



Figure I-2



**FIGURE I-2**  
 Conceptual Design of Typical Fill Cap Barrier  
 Vegetation Protective Cover  
 (City Parks)  
 Promontory Park North,  
 Toronto, Ontario

NOT TO SCALE

Figure I-3

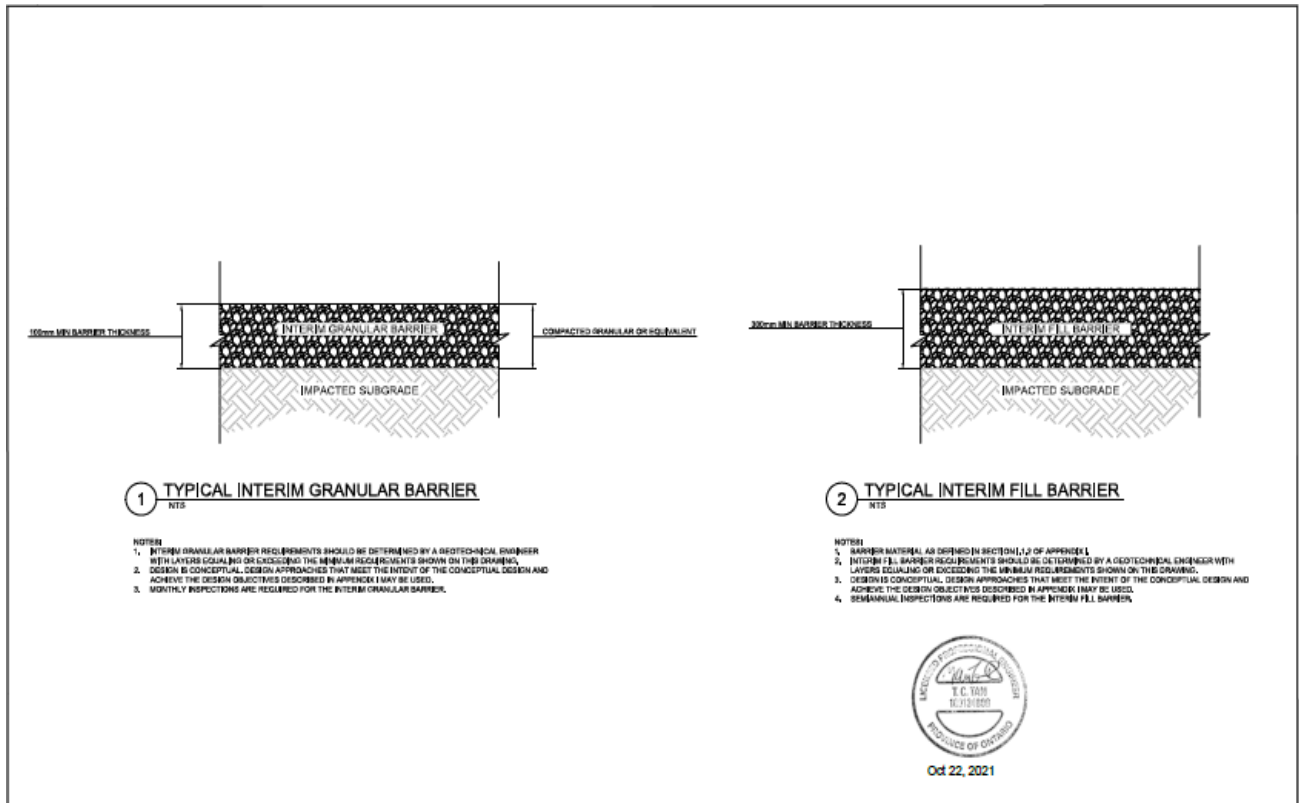

FIGURE I-3  
Conceptual Design of Interim Cap Barrier

Parsons Park North  
Toronto, Ontario

Figure I-4

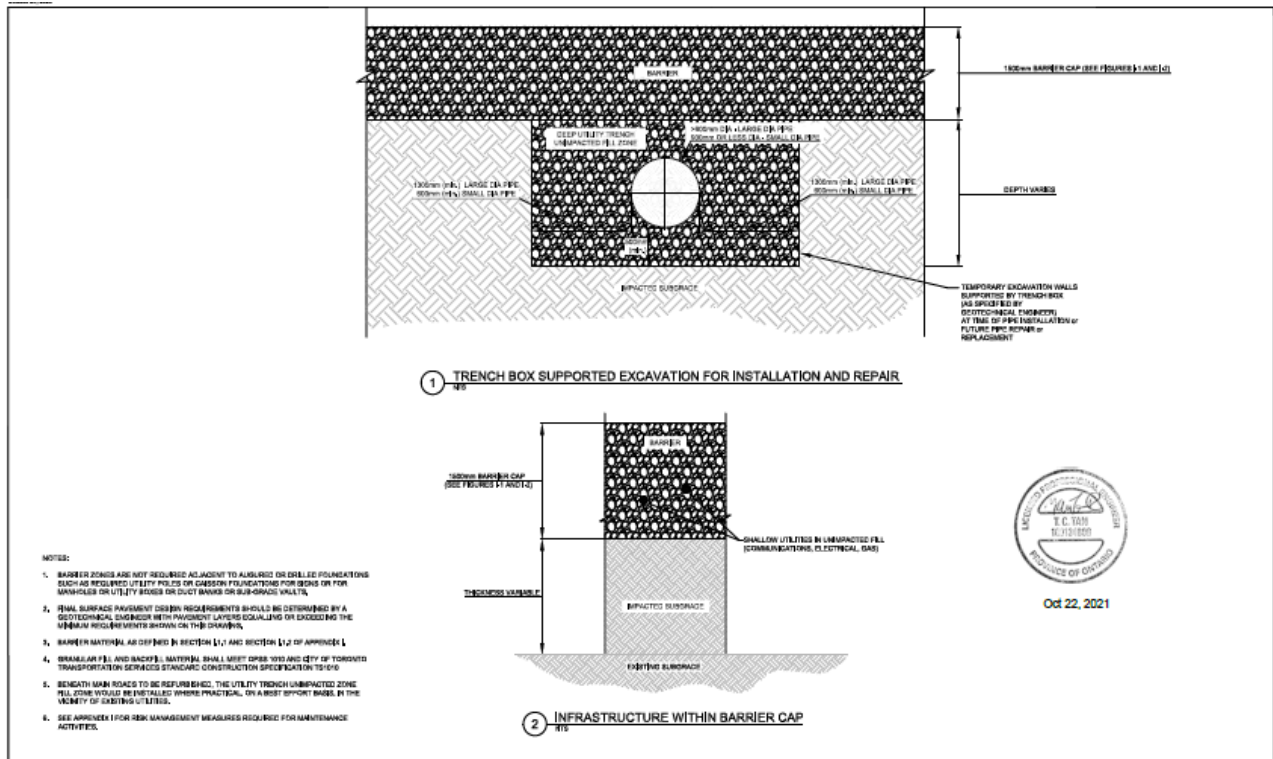
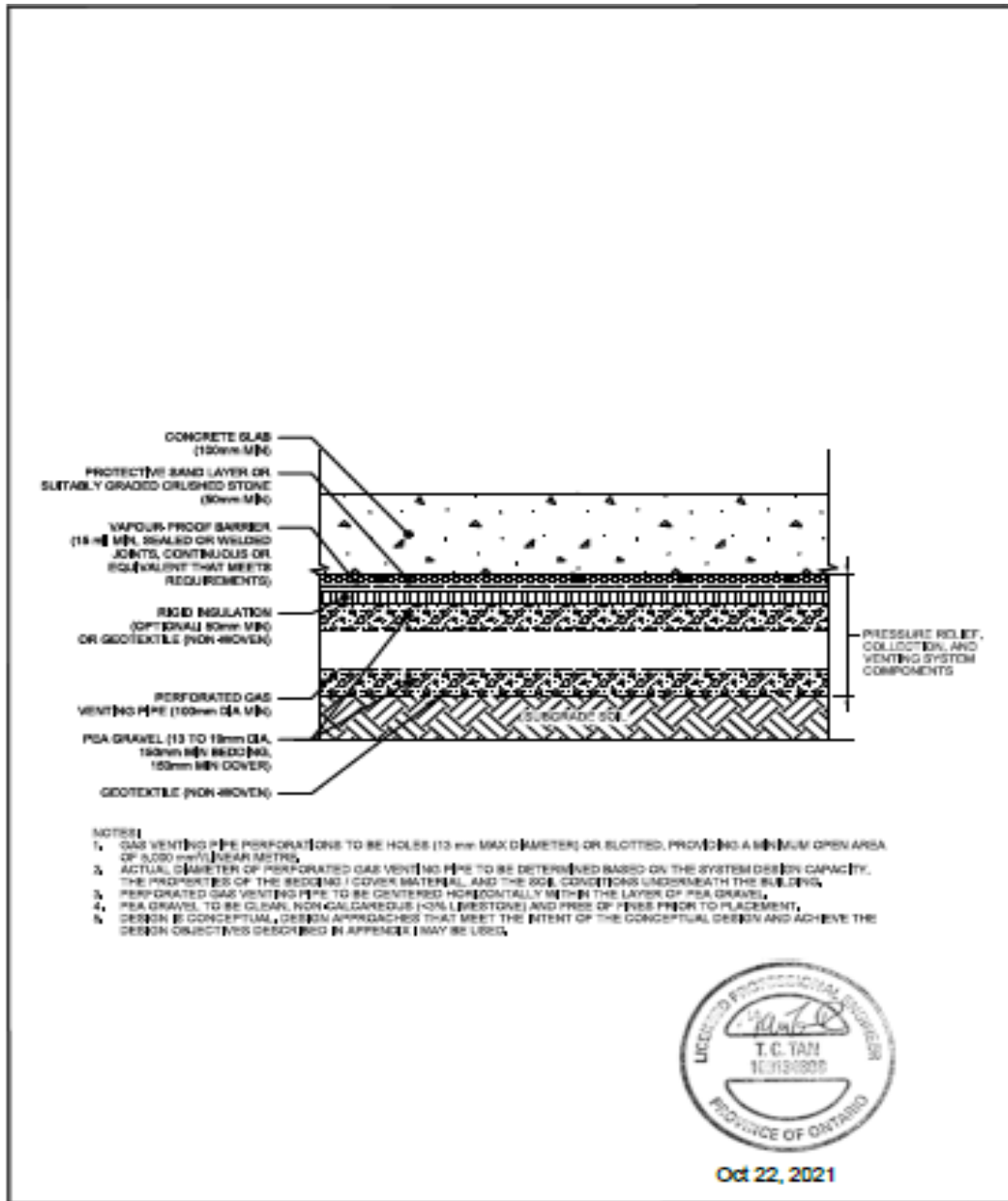

FIGURE I-4  
 Conceptual Design of Typical RII Cap Barrier  
 Utility Construction  
 Promontory Park North,  
 Toronto, Ontario

Figure I-5



**FIGURE I-5**  
Conceptual Design in Cross-Section View  
Passive Relief, Collection, and Venting System

Princess Park North,  
Toronto, Ontario

Figure I-6

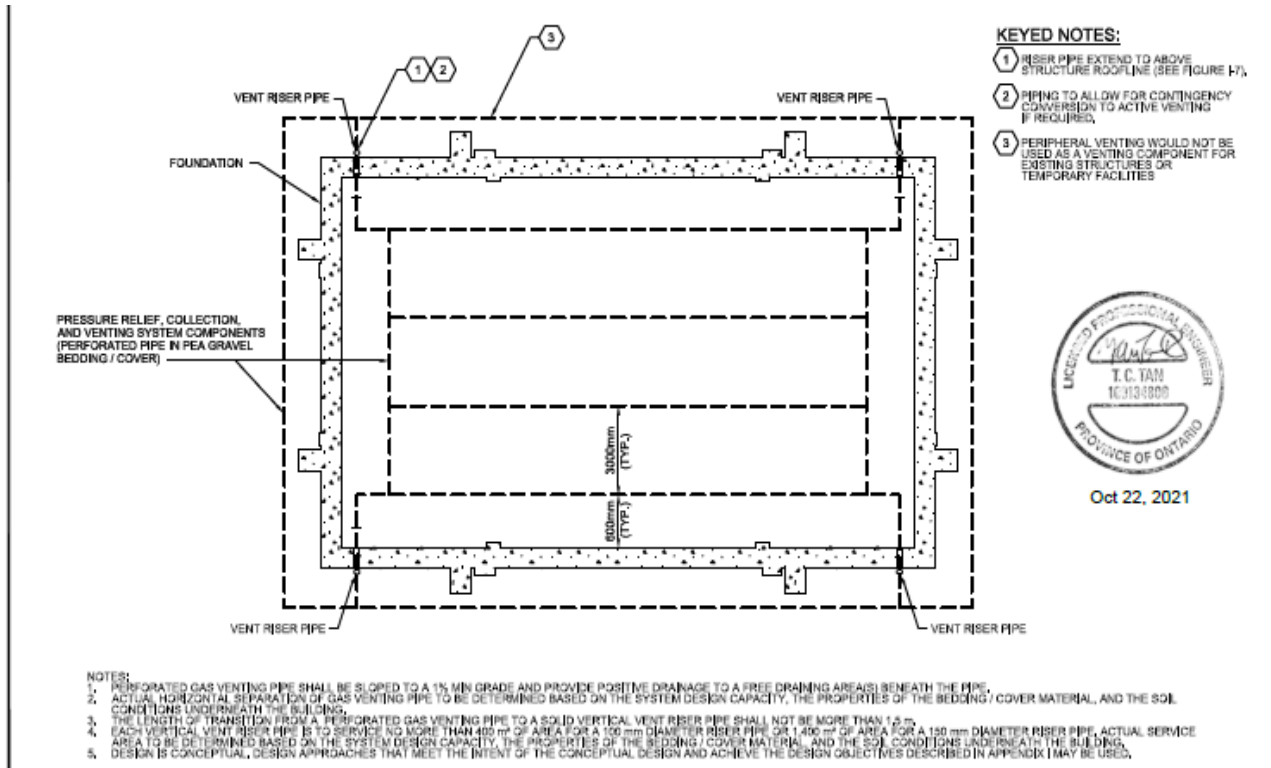

**FIGURE I-6**  
 Conceptual Design in Plan View  
 Pressure Relief, Collection, and Venting System

Promontory Park North,  
 Toronto, Ontario

Figure I-7

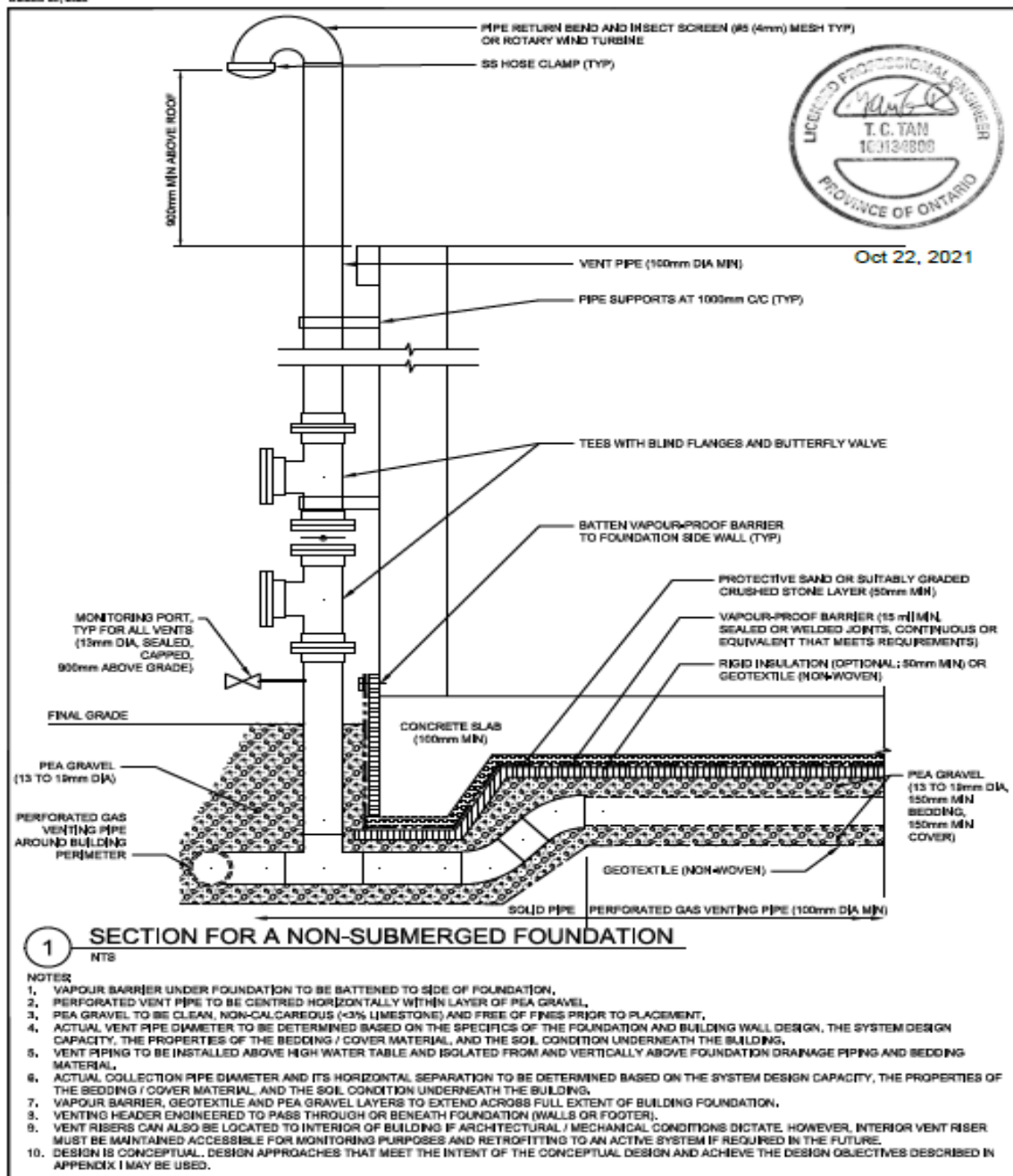

**FIGURE I-7**  
 Conceptual Design for Unsaturated Conditions  
 Passive Relief, Collection, and Venting System

Promontory Park North,  
 Toronto, Ontario

Figure I-9

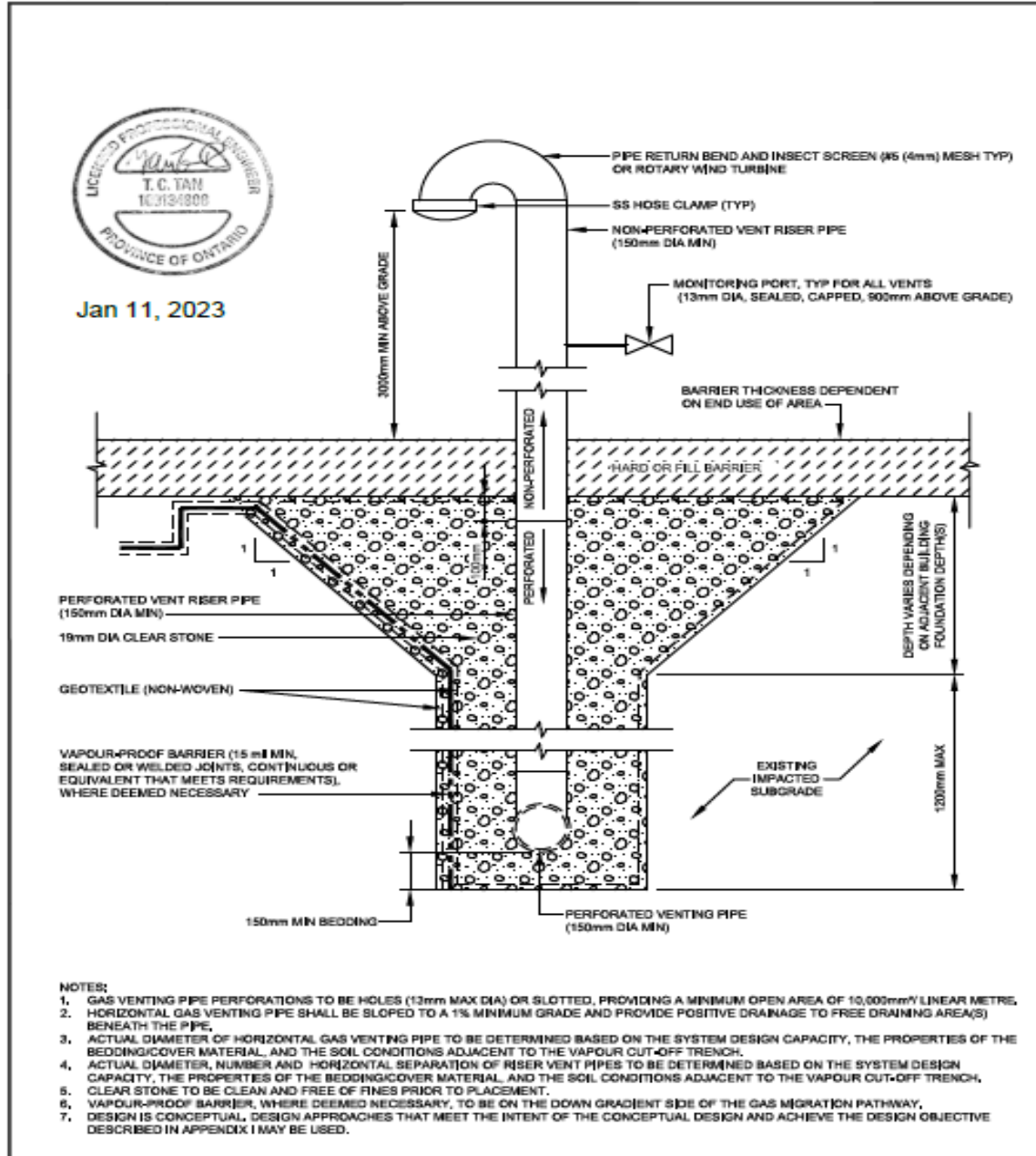

**FIGURE I-9**  
 Conceptual Design of Vapour Cut-off Trench  
 Passive Relief, Collection, and Venting System

Promontory Park North,  
 Toronto, Ontario

Figure I-10

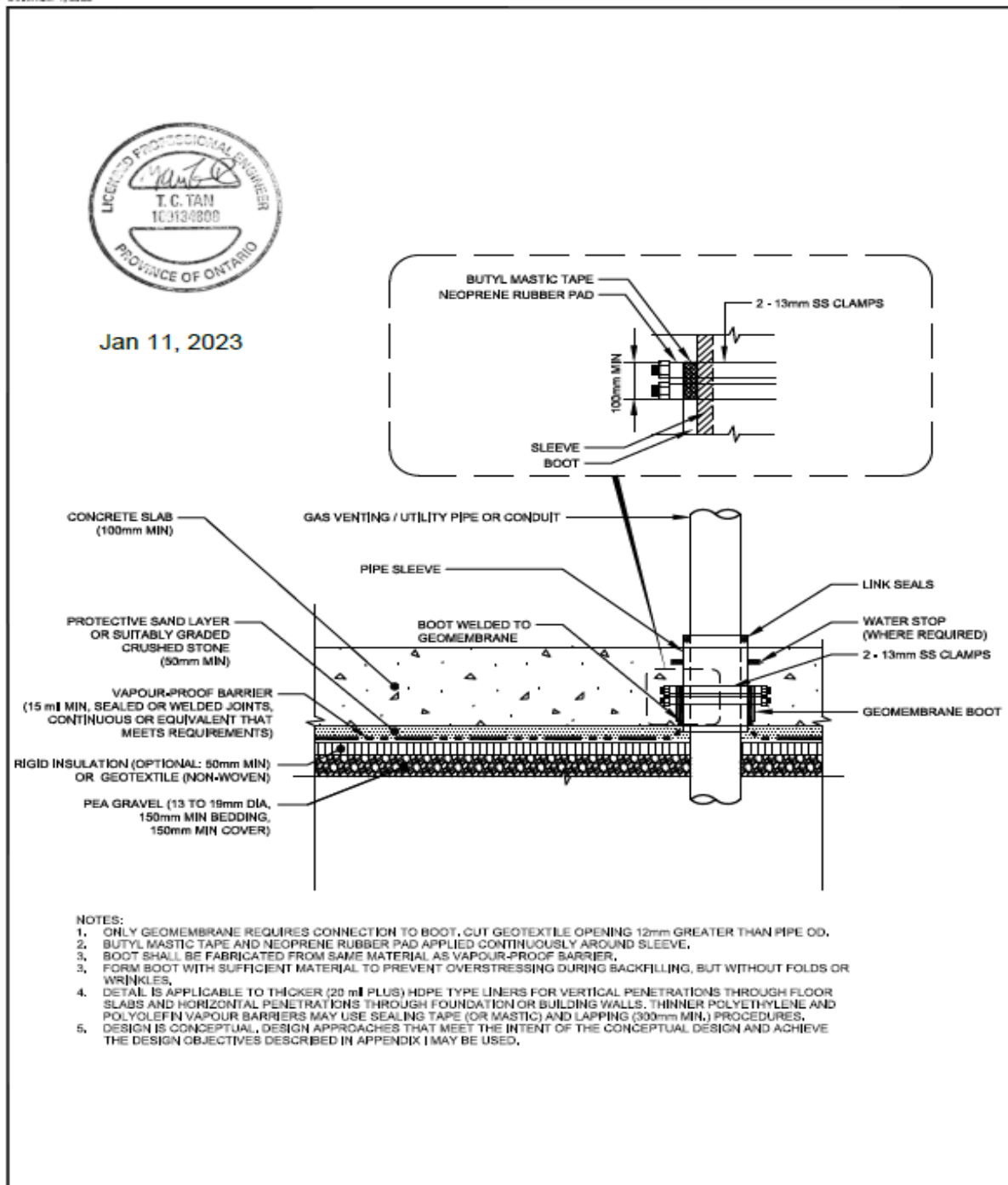
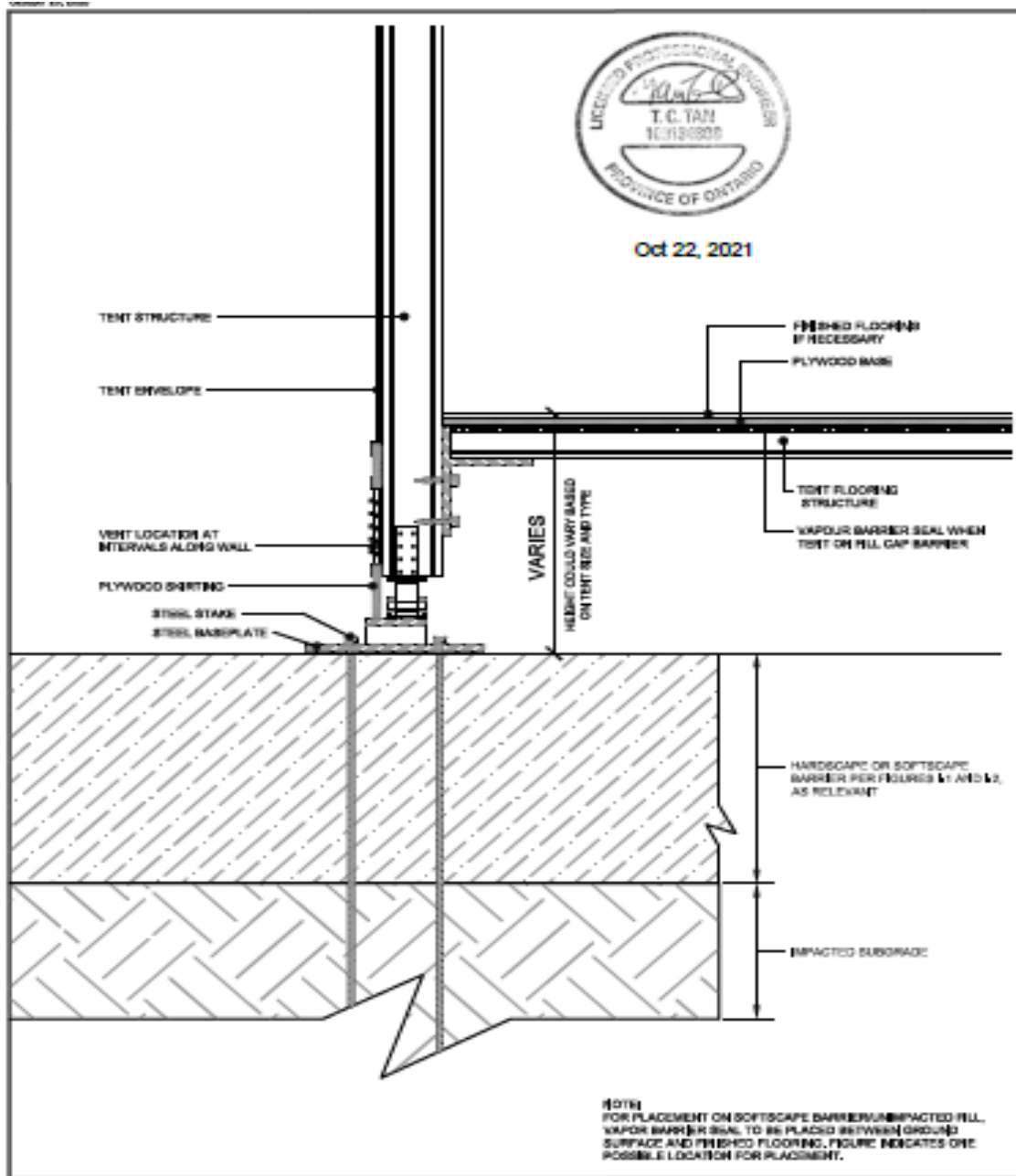

**FIGURE I-10**  
 Conceptual Design for Conduit and Pipe Penetrations  
 Passive Relief, Collection, and Venting System

*Promontory Park North,  
 Toronto, Ontario*



Figure 1-11



**FIGURE I-11**  
Conceptual Design of Vapour Mitigation System for Temporary Tent Structures

Premontary Park North,  
Toronto, Ontario

**Figure 1-2: Community-Based Risk Assessment Boundaries**

