

Ministry of the Environment,
Conservation and Parks
Ministère de l'Environnement, de la Protection
de la nature et des Parcs

Certificate of Property Use

Issued under the authority of the *Environmental Protection Act*, R.S.O. 1990, c.
E.19, sections 168.6 (CPU) and 197 (Order)

Certificate of Property Use number: **8452-BHMMZD**
Risk Assessment number: **7812-AP7QRK**

Owner: 1150735 Ontario Ltd.
292 James Street North
Hamilton, Ontario
L8R 2L3

Site: 108–112 James Street North and 115 Hughson Street North, Hamilton, Ontario

Legal Description:

PART LOT 3, JAMES HUGHSON SURVEY (UNREGISTERED) W/S HUGHSON ST AS IN CD396719; PART LOT 2 JAMES HUGHSON SURVEY (UNREGISTERED) E/S JAMES ST PART 1, PLAN 62R10419; PT LT 2 JAMES HUGHSON SURVEY (UNREGISTERED) W/S HUGHSON ST PT 4, 5, 6 62R10419; PT LT 3 JAMES HUGHSON SURVEY (UNREGISTERED) W/S HUGHSON ST PT 2, 3 62R10419; CITY OF HAMILTON

Being all of Property Identifier Number (PIN): 17165-0291 (LT)

This Certificate of Property Use and section 197 Order set out the requirements regarding the above-noted Property and the Risk Assessment carried out in relation to the Property which was assigned the number noted above and is described in more detail in Part 1 below.

Refer to Part 1 of the CPU, Interpretation, for the meaning of all the defined capitalized terms that apply to the CPU.

Part 1: Interpretation

In the CPU the following terms shall have the meanings described below:

“Act” means the *Environmental Protection Act*, R.S.O. 1990, c. E.19.

“Adverse Effect” has the same meaning as in the Act; namely,

- (a) impairment of the quality of the natural environment for any use that can be made of it,
- (b) injury or damage to property or to plant or animal life,
- (c) harm or material discomfort to any person,
- (d) an adverse effect on the health of any person,
- (e) impairment of the safety of any person,
- (f) rendering any property or plant or animal life unfit for human use,
- (g) loss of enjoyment of normal use of property, and
- (h) interference with the normal conduct of business.

“Building(s)” means an enclosed structure(s) occupying an area greater than ten square metres consisting of a wall or walls, roof and floor.

“Building Area” means the horizontal area of a Building at Grade within the outside surface of the exterior wall or walls.

“Building Code” means Ontario Regulation 332/12 (Building Code) as amended to January 1, 2015, made under the *Building Code Act*, 1992, S.O. 1992, c. 23.

“Certificate of Property Use” or “CPU” means this certificate of property use bearing the number **8452-BHMMZD** issued for the Property by the Director under section 168.6 of the Act, as it may be amended from time to time.

“Competent Person” has the same meaning as in the *Occupational Health and Safety Act*, R.S.O. 1990, c. O.1.

“Contaminant of Concern” & “COC” has the meaning as set out in Item 3.2 of this CPU.

“Director” means a person in the Ministry appointed as a director for the purpose of issuing a certificate of property use under section 168.6 of the Act.

“EBR” means the *Environmental Bill of Rights*, 1993, .S.O. 1993, c.28.

“Grade” has the same meaning as in the Building Code.

“Impacted Soils” means soil in which one or more Contaminants are present at concentrations greater than the soil criteria identified for coarse textured soils in a **Residential, Parkland, Institutional** land use on **Table 3: Full Depth Generic Site**

Condition Standards in a Non-Potable Ground Water Condition of the Ministry's *Soil, Ground Water and Sediment Standards for Use Under Part XV.1 of the Environmental Protection Act* published by the Ministry and dated April 15, 2011.

"Licensed Professional Engineer" means a person who has obtained the appropriate education and training and has demonstrated experience and expertise in the areas related to the work required to be carried out in this CPU and holds a licence, limited licence or temporary licence under the Professional Engineers Act, R.S.O. 1990, c. P.28.

"Minister" means the Minister of the Ministry.

"Ministry" means the ministry of the government of Ontario responsible for the administration of the Act, currently named the Ministry of the Environment, Conservation and Parks.

"O. Reg. 153/04" means Ontario Regulation 153/04, "Record of Site Condition – Part XV.1 of the Act" made under the Act.

"Owner" means the owner(s) of the Property, beginning with the person(s) to whom the Certificate of Property Use for the Property is first issued by the Director under section 168.6 of the Act based on the Risk Assessment, and any subsequent owner of the Property.

"OWRA" means the *Ontario Water Resources Act, R.S.O. 1990, c.0.40*.

"Property" means the property that is the subject of the CPU and described in the "Property" section on page 1 above and shown on **Figure 1** of Schedule A attached to and forming part of this CPU.

"Property Specific Standards" means the property specific standards established for the Contaminants of Concern set out in the Risk Assessment and in section 3.2 of the CPU.

"Provincial Officer" has the same meaning as in the Act, namely, a person who is designated by the Minister as a provincial officer for the purposes of the Act and the regulations.

"Qualified Person" means a person who meets the qualifications set out in subsection 5 (2) of O. Reg. 153/04.

"Reg. 347" means Ontario Regulation R.R.O. 1990, Reg. 347, "General — Waste Management" made under the Act

"Risk Assessment" (RA) means the Risk Assessment No. **7812-AP7QRK** accepted by the Director on **November 1, 2019** ("RA"), and set out in the following documents:

- “Risk Assessment Pre-Submission Report of 108-112 James Street North and 115 Hughson Street North, Hamilton, Ontario”, report prepared by MTE Consultants Inc., dated July 7, 2017
- “Risk Assessment Report for 108-112 James Street North and 115 Hughson Street North, Hamilton, Ontario”, report prepared by MTE Consultants Inc., dated July 6, 2018
- “Revised Risk Assessment for 108-112 James Street North and 115 Hughson Street North, Hamilton, Ontario”, report prepared by MTE Consultants Inc., dated March 12, 2019
- “Second Revised Risk Assessment Report for 108-112 James Street North and 115 Hughson Street North, Hamilton, Ontario”, report prepared by MTE Consultants Inc., dated August 2, 2019

“Risk Management Measures” means the risk management measures specific to the Property described in the Risk Assessment and/or Part 4 of the CPU.

“Risk Management Plan” means the final version of the risk management plan as set out in section 7 and **Appendix L** of the “Risk Assessment” report dated **August 2, 2019**.

“Storage Garage” has the same meaning as in the Building Code.

“Tribunal” has the same meaning as in the Act. namely, the Environmental Review Tribunal.

“Unimpacted Soil” means soil that meets the criteria identified for **coarse textured soils** in **Residential, Parkland, Institutional** property use on **Table 3: Full Depth Generic Site Condition Standards in a Non-Potable Ground Water Condition** of the Ministry’s *Soil, Ground Water and Sediment Standards for Use Under Part XV.1 of the Environmental Protection Act* published by the Ministry and dated April 15, 2011.

Part 2: Legal Authority

- 2.1 Section 19 of the Act states that a certificate of property use is binding on the executor, administrator, administrator with the will annexed, guardian of property or attorney for property of the person to whom it was directed, and on any other successor or assignee of the person to whom it was directed.
- 2.2 Subsection 132(1.1) of the Act states that the Director may include in a certificate of property use a requirement that the person to whom the certificate is issued provide financial assurance to the Crown in right of Ontario for any one or more of,

- a. the performance of any action specified in the certificate of property use;
- b. the provision of alternate water supplies to replace those that the Director has reasonable and probable grounds to believe are or are likely to be contaminated or otherwise interfered with by a contaminant on, in or under the property to which the certificate of property use relates; and
- c. measures appropriate to prevent adverse effects in respect of the property to which the certificate of property use relates.

2.3 Section 168.6 (1) of the Act states that if the Director accepts a risk assessment relating to a property, he or she may, when giving notice under clause 168.5 (1)(a), issue a certificate of property use to the owner of the property, requiring the owner to do any of the following things:

1. Take any action specified in the certificate that, in the Director's opinion, is necessary to prevent, eliminate or ameliorate any adverse effect on the property, including installing any equipment, monitoring any contaminant or recording or reporting information for that purpose.
2. Refrain from using the property for any use specified in the certificate or from constructing any building specified in the certificate on the property.

2.4 Subsection 168.6(2) of the Act states that a certificate of property use shall not require an owner of property to take any action that would have the effect of reducing the concentration of a contaminant on, in or under the property to a level below the level that is required to meet the standards specified for the contaminant in the risk assessment.

2.5 Subsection 168.6(3) of the Act states that the Director may, on his or her own initiative or on application by the owner of the property in respect of which a certificate has been issued under subsection 168.6(1),

- a. alter any terms and conditions in the certificate or impose new terms and conditions; or
- b. revoke the certificate.

2.6 Subsection 168.6(4) of the Act states that if a certificate of property use contains a provision requiring the owner of the property to refrain from using the property for a specified use or from constructing a specified building on the property,

- a. the owner of the property shall ensure that a copy of the provision is given to every occupant of the property;
- b. the provision applies, with necessary modifications, to every occupant of the property who receives a copy of the provision; and

- c. the owner of the property shall ensure that every occupant of the property complies with the provision.
- 2.7 Subsection 197(1) of the Act states that a person who has authority under the Act to make an order or decision affecting real property also has authority to make an order requiring any person with an interest in the property, before dealing with the property in any way, to give a copy of the order or decision affecting the property to every person who will acquire an interest in the property as a result of the dealing.
- 2.8 Subsection 197(2) of the Act states that a certificate setting out a requirement imposed under subsection 197(1) may be registered in the proper land registry office on the title of the real property to which the requirement relates, if the certificate is in a form approved by the Minister, is signed or authorized by a person who has authority to make orders imposing requirements under subsection 197(1) and is accompanied by a registrable description of the property.
- 2.9 Subsection 197(3) of the Act states that a requirement, imposed under subsection 197(1) that is set out in a certificate registered under subsection 197(2) is, from the time of registration, deemed to be directed to each person who subsequently acquires an interest in the real property.
- 2.10 Subsection 197(4) of the Act states that a dealing with real property by a person who is subject to a requirement imposed under subsection 197(1) or 197(3) is voidable at the instance of a person who was not given the copy of the order or decision in accordance with the requirement.

Part 3: Background

- 3.1 The Risk Assessment (RA) was undertaken for the Property on behalf of the Owner to assess the human health risks and ecological risks associated with the presence or discharge of contaminants on, in or under the Property and to identify appropriate Risk Management Measures to be implemented to ensure that the Property is suitable for the intended uses: **Residential, Parkland, Institutional** as defined in O. Reg. 153/04.
- 3.2 The contaminants on, in or under the Property that are present either above the **Table 3: Full Depth Generic Site Condition Standards in a Non-Potable Ground Water Condition** of the *Soil, Ground water and Sediment Standards for Use under Part XV.1 of the Act* published by the Ministry and dated April 15, 2011 for **coarse textured soils** in a **Residential, Parkland, Institutional** property use or for which there are no such standards, are set out in the Risk Assessment (Contaminants of Concern). The Property Specific Standards for these Contaminants of Concern are set out in **Table 1A and 1B of Schedule A** which is attached to and forms part of this CPU.

- 3.3 I am of the opinion, for the reasons set out in the Risk Assessment that the Risk Management Measures described therein and outlined in Part 4 of the CPU are necessary to prevent, eliminate or ameliorate an Adverse Effect on the Property that has been identified in the Risk Assessment.
- 3.4 The Risk Assessment indicates the presence of Contaminants of Concern in soil and groundwater which require on-going restriction of land use and pathway elimination. As such, it is necessary to restrict the use of the Property and impose building restrictions and implement Risk Management Measures as set out in the Risk Assessment and in Part 4 of the CPU.
- 3.5 I believe for the reasons set out in the Risk Assessment that it is also advisable to require the disclosure of this CPU and the registration of notice of the CPU on title to the Property as set out in the section 197 order requirements in Item 4.6 of the CPU.

Part 4: Director Requirements

Pursuant to the authority vested in me under subsection 168.6(1) of the Act, I hereby require the Owner to do or cause to be done the following:

Risk Management Measures

- 4.1 Implement, and thereafter maintain or cause to be maintained, the Risk Management Measures.
- 4.2 Without restricting the generality of the foregoing in Section 4.1, carry out or cause to be carried out the following key elements of the Risk Management Measures:
- 4.2.1 Prior to the occupancy of any new Building(s) to be constructed on the Property, a barrier shall be installed across the entire Property to prevent exposures to COCs occurring on the Property. The barriers are to be maintained for as long as COCs are present on the Property and may consist entirely of a fill cap, or entirely of a hard cap, or of a hard cap in some areas of the Property and a fill cap in other areas of the Property. Barriers shall be constructed in accordance with **Figure 2** of Schedule A of this CPU and the Risk Management Plan and be comprised of:
- i. **fill cap** - capping of areas on the Property where Impacted Soils are present at or within 1.0 m below the soil surface with a minimum of 1.0 m of cover, consisting of at least 0.5 m of Unimpacted soil and, above the Unimpacted Soil, may also include up to 0.5 m of non-soil surface treatment such as asphalt or concrete and aggregate;

- ii. **hard cap** - capping of areas on the Property where Impacted Soils are not covered by at least 1.0 m of Unimpacted Soil with asphalt, concrete, a building slab, or a building foundation and floor slab, consisting of at least 150 mm of Ontario Provincial Standard Specification (OPSS) Granular "A" product or equivalent material overlain by at least 75 mm of hot mix asphaltic concrete or concrete.
- iii. the planting of vegetation with rooting depths greater than 1 metre below Grade surface shall be installed in accordance with the Risk Management Plan and as set out on **Figure 3** of Schedule A of this CPU.
- iv. the use of any native soils on the Property in the construction of the barriers set out by this part of the CPU is only possible if the soil is determined to be Unimpacted Soil in accordance with Section 36 of Schedule E of the Regulation.

4.2.2 Prior to the development of all or any part of the Property, the Owner shall install fencing and implement dust control measures for any part of the Property requiring barriers specified by Item 4.2.1 of this CPU but which has not been covered, so as to restrict access to the part that is fenced and prevent exposure to COCs at the Property. The fencing and dust control measures are to be maintained until the installation of the barriers described by Item 4.2.1 of this CPU within the fenced part is complete.

4.2.3 Within 90 days of completion of the installation of the barriers described by Item 4.2.1 of this CPU, the Owner shall submit to the Director, written confirmation signed by a Licensed Professional Engineer that the barriers have been installed in accordance with the requirements of the Risk Management Plan and this CPU along with final design specifications/drawings and/or as-built drawings.

4.2.4 The Owner shall prepare and maintain a site plan of the Property, prepared by a Licensed Professional Engineer, and be available for inspection upon request by a Provincial Officer, showing the Property, any fencing, and the location, type and design of the barriers described by Item 4.2.1 of this CPU, including cross-sectional drawings showing the vertical and lateral extent of the barriers; and which is,

- i. delivered to the Owner before use of all or any part of the property begins, or within 90 days following completion of covering of all or any part of the property, whichever is earlier; and
- ii. updated and delivered to the Owner within 30 days following making any alteration to the location, design or extent of the barrier, or other relevant feature shown on the site plan.

4.2.5 An inspection and maintenance program shall be implemented to ensure the continuing integrity of the barriers described by Item 4.2.1 of this CPU for as long as the COCs are present on the Property. The inspection program shall include semi-annual (spring and fall) inspections of the barrier's integrity in accordance with the inspection and maintenance program set out in the Risk Management Plan. Any barrier deficiencies shall be repaired forthwith in accordance with the Risk Management Plan. If cracks, breaches or any loss of integrity in the barriers cannot be repaired or addressed in a timely manner, contingency measures shall be implemented to ensure no exposure to the COCs present on the Property. The restoration of any damaged portions of the barriers shall meet the specifications set out, at minimum, in Item 4.2.1 of this CPU and the Risk Management Plan. In the event of a repair to a barrier, the Owner shall submit to the Director written confirmation prepared and signed by a Licensed Professional Engineer that the barriers have been repaired in accordance with the requirements of this CPU and the Risk Management Plan. The written confirmation shall also include a description of any contingency measures put in place and shall be submitted to the Director within 30 days of the completion of any barrier repairs and/or restorations. The Owner shall keep records of the inspections and maintenance and make them available for review by the Ministry upon request.

4.2.6 The Owner shall prepare a written soil and groundwater management plan (herein "Plan") for the Property, prepared by a Qualified Person and be implemented during intrusive activities to prevent exposure to or uncontrolled movement or discharge of the Contaminants of Concern in soil or ground water at the Property. The Plan must be delivered to the Owner prior to undertaking any intrusive activities at the property, and if alterations are made to the Plan, the Plan must be updated and delivered to the Owner within 30 days following the alterations to the Plan. The Plan shall include the following components:

- i. oversight by a Qualified Person;
- ii. procedures and timing for implementing the plan, including the supervision of persons implementing the plan;
- iii. requirements that all excavation shall be done in accordance with the Occupational Health and Safety Act, including requirements for shoring and dewatering;
- iv. measures to control dust and prevent tracking of soil by vehicles and persons from the Property, including the cleaning of equipment and vehicles;

- v. measures, in addition to any applicable measures specified by O. Reg. 153/04 and O. Reg. 406/19, to manage soil excavated at the Property and any soil brought to or removed from the Property, including:
 - a. characterizing for contaminant quality all excavated soil and any soil brought to the Property, including determining whether the soil:
 - i. is Unimpacted Soil;
 - ii. meets the Property Specific Standards; or
 - iii. exceeds the Property Specific Standards;
 - b. managing excavated soil separately from any soil brought to the Property in accordance with the applicable requirements of O. Reg. 406/19, including any excavated soil that is to be:
 - i. used as Unimpacted Soil at the Property;
 - ii. removed from the Property for off-site storage or processing but is to be returned to the Property; or
 - iii. removed from the Property for off-site reuse or disposal; and
 - c. stockpiling of excavated soil and any soil brought to the Property in separate designated areas that:
 - i. reflect the distinctions described in Items 4.2.6 v. (a) and (b) of this CPU;
 - ii. have been lined and covered, as appropriate, to prevent uncontrolled movement or discharge of the COCs;
 - iii. have been bermed or fenced, as appropriate, to restrict access by persons; and
 - iv. have storm water runoff controls in place to minimize storm water runoff contacting stockpiled soil, with provision for discharge of storm water runoff to a sanitary sewer or to other approved treatment if needed;
- v. measures to manage storm water and any ground water from dewatering at the Property to prevent the movement of entrained soil and Contaminants of Concern within and away from the Property, including, in addition to any applicable measures specified pursuant to other applicable law or other instruments, measures such as silt fences, filter socks for catch basins and utility covers, and provision for discharge to a sanitary sewer or to other approved treatment if needed; and
- vi. measures for when there is a need for temporary construction dewatering to keep an excavation free of groundwater; dewatering activities will be conducted in a manner that will not involve any discharges to the natural environment. Excess water will be

temporarily stored on-site prior to off-site removal to an approved water treatment facility or treated and discharged to the sanitary sewer through an agreement with the City of Hamilton.

- vii. recording, in writing, the soil, storm water and any ground water management measures undertaken, in addition to any applicable record keeping requirements specified in O. Reg. 153/04 or pursuant to other applicable law or other instruments, to be retained by the Owner, and be available for inspection upon request by a Provincial Officer, including:
 - a. dates and duration of the intrusive activities being undertaken;
 - b. weather and site conditions during the intrusive activities;
 - c. the location and depth of excavation activities, and dewatering activities, if any;
 - d. dust control and soil tracking control measures;
 - e. characterization results for excavated soil and any soil brought to or removed from the Property, and for any ground water from dewatering;
 - f. soil management activities including soil quantities excavated and brought to and removed from the Property, and stockpile management and storm water runoff control;
 - g. management activities for any ground water from dewatering;
 - h. names and contact information for the Qualified Persons and on-site contractors involved in the intrusive activities;
 - i. names and contact information for any haulers and receiving sites for soil and any ground water removed from the Property, and for haulers and source sites of any soil brought to the Property; and
 - j. any complaints received relating to the intrusive activities; including the soil, storm water and any ground water management activities.

4.2.7 Refrain from constructing any Building on the Property unless the Building includes a Storage Garage, and:

- i. the Storage Garage is constructed with at least one level below the Grade of the Building; and
- ii. the Storage Garage area covers the entire Building Area at Grade; and
- iii. the Storage Garage complies with all applicable requirements of the Building Code, such as the provisions governing:
 - a. the design of a mechanical ventilation system as set out in Division B, Article 6.2.2.3. (Ventilation of Storage and Repair Garages) of the Building Code; and
 - b. the interconnection of air duct systems as set out in Division B, Sentence (2) of Article 6.2.3.9. (Interconnection of Systems) of the Building Code; and

- c. air leakage as set out in Division B, Section 5.4. (Air Leakage) of the Building Code; and
 - iv. The mechanical ventilation system for the Storage Garage is designed to provide, and provides at all times, a continuous supply of outdoor air at a rate of not less than 3.9 litres per second for each square metre of floor area as set out in the Risk Management Plan
- 4.2.8 The owner shall implement a soil and sub-slab vapour monitoring program (herein “program”) in accordance with the Risk Management Plan for the existing “Tivoli Theatre” and “House” Buildings located on the Property as indicated on Figure 4, Schedule A of this CPU. All monitoring results shall be compared to the applicable criteria set out on **Table 1C**, Schedule A of this CPU. Specifically, the program shall include, but not be limited to, the following components:
- i. Be overseen by a Qualified Person.
 - ii. Soil vapour measurements will begin within three months of the completion of the “Tivoli Theatre” Building restoration.
 - iii. Sub-slab vapour measurements will begin within three months of the “House” Building restoration.
 - iv. All measurements will be carried out quarterly in the first year and semi-annually in the second year and years thereafter, within the quarters which generated the highest and next highest results in the first year of monitoring.
 - v. Samples shall be collected from the locations identified on Figure 4, Schedule A of this CPU and as described in the Risk Management Plan.
 - vi. If a measured concentration exceeds the values set out on **Table 1C** Schedule A of this CPU, at any of the locations described by Item 4.2.8. v. of this CPU, then the Owner shall notify the Director within 10 days and collect an additional (confirmatory) sample at the location(s) where the exceedance occurred within 15 days of receiving analytical results and undertake the following as applicable:
 - 1. If none of the concentrations of the COCs exceed the values set out on **Table 1C**, Schedule A of this CPU on the confirmatory monitoring event, then monitoring shall be carried out as described by Item 4.2.8 i., ii., iii., iv and v. of this CPU;
 - 2. If any of the concentrations of the COCs exceed the values set out on **Table 1C**, Schedule A of this CPU, on the confirmatory

monitoring event, the Owner shall notify the Director within 10 days of receiving analytical results and within 30 days of receiving the analytical results have a Licensed Professional Engineer submit a work plan with timelines to the Director for further investigations and recommendations (contingency actions) to minimize/mitigate vapour intrusion into the Building(s) on the Property.

3. Upon the Owner receiving written approval from the Director regarding the contingency plan submitted as required by Item 4.2.8 vi. 2., the Owner shall forthwith implement the plan and provide confirmation to the Director. The contingency plan shall be completed under the supervision of a Licensed Professional Engineer.
 - vii. Upon the occurrence of two consecutive years of monitoring results that are less than the values set out on **Table 1C**, Schedule A of this CPU, at the locations described by Item 4.2.8 v. of this CPU; the Owner may apply to the Director to alter the frequency or revoke the program in accordance with Item 5.2 a) of this CPU.
 - viii. The Owner shall keep a copy of all sampling data available for inspection by a Provincial Officer upon request.
- 4.2.9 The owner shall incorporate utility trench dams as described by the Risk Management Plan and shown conceptually on **Figure 5**, Schedule A to prevent the migration of soil vapour into new Buildings constructed on Property and to prevent the migration of soil vapour off-Property.
- 4.2.10 A Health and Safety Plan (HASP) shall be developed by a Competent Person, in consultation with a Qualified Person and implemented prior to all intrusive activities potentially in contact with or exposing COCs identified on the Property or portion (s) of the Property. A copy of the plan shall be maintained at the Property for the duration of all intrusive activities. The HASP shall be prepared in accordance with the requirements set out in the Risk Management Plan and include, but not be limited to, occupational hygiene requirements, personal protective equipment, contingency plans and contact information. The Owner shall retain a copy of the HASP to be available for review upon request.
- 4.2.11 Before April 30th of the year following the year in which this CPU is issued and annually thereafter, the Owner shall prepare an annual report documenting the activities relating to the Risk Management Measures undertaken during the previous calendar year. This report is to be prepared by a Qualified Person and be made available upon request by a Provincial Officer. The report shall include the following information:

- i. Inspection and maintenance activities for the barriers described by Item 4.2.1 of this CPU;
- ii. Soil and ground water management activities as described by Item 4.2.6 of this CPU;
- iii. Confirmation that the Storage Garage covers the entire Building footprint and is ventilated in accordance to Item 4.2.7 of this CPU;
- iv. The results of the sub-slab and soil vapour monitoring activities described by Item 4.2.8 of this CPU;
- v. Any other information determined to be necessary by the Qualified Person.

Site Changes

4.3 In the event of a change in the physical site conditions or receptor characteristics at the Property that may affect the Risk Management Measures and/or any underlying basis for the Risk Management Measures, forthwith notify the Director of such changes and the steps taken, to implement, maintain and operate any further Risk Management Measures as are necessary to prevent, eliminate or ameliorate any Adverse Effect that will result from the presence on, in or under the Property or the discharge of any Contaminant of Concern into the natural environment from the Property. In support of this work, a new risk assessment may need to be completed in accordance with O. Reg. 153/04 and submitted to the Ministry for acceptance. An amendment to the CPU will be issued to address the changes set out in the notice received and any further changes that the Director considers necessary in the circumstances.

Reports

4.4 The Owner shall retain a copy of any reports required under the CPU, for a period of seven (7) years from the date the report is created and within ten (10) days of the Director or a Provincial Officer making a request for a report, provide a copy to the requesting Director or Provincial Officer.

Property Requirement

4.5 For the reasons set out in the CPU and pursuant to the authority vested in me under subsection 197(1) of the Act, I hereby order you and any other person with an interest in the Property, before dealing with the Property in any way, to give a copy of the CPU, including any amendments thereto, to every person who will acquire an interest in the Property, as a result of the dealing.

Certificate of Requirement

4.6 Within fifteen (15) days from the date of receipt of a certificate of requirement, issued under subsection 197(2) of the Act completed as outlined in Schedule B,

register the certificate of requirement on title to the Property in the appropriate land registry office.

- 4.7 Within five (5) days after registering the certificate of requirement, provide to the Director a copy of the registered certificate and of the parcel register(s) for the Property confirming that registration has been completed.

Owner / Occupant Change

- 4.8 While the CPU is in effect, the Owner shall, forthwith report in writing to the Director any changes of ownership of the Property except that while the Property is registered under the Condominium Act, 1998, S.O.1998 c.19, as amended, no notice shall be given of changes in the ownership of individual condominium units or any appurtenant common elements on the Property.

Financial Assurance

- 4.9 The Director has not included in the CPU a requirement that the Owner provide financial assurance to the Crown in right of Ontario.

Part 5: General

- 5.1 The requirements of the CPU are severable. If any requirement of the CPU or the application of any requirement to any circumstance is held invalid, such finding does not invalidate or render unenforceable the requirement in other circumstances nor does it invalidate or render unenforceable the other requirements of the CPU.
- 5.2 An application under subsection 168.6(3) of the Act to,
a) alter any terms and conditions in the CPU or impose new terms and conditions; or
b) revoke the CPU;
shall be made in writing to the Director, with reasons for the request.
- 5.3 The Director may amend the CPU under subsections 132(2) or (3) of the Act to change a requirement as to financial assurance, including that the financial assurance may be increased or provided, reduced or released in stages. The total financial assurance required may be reduced from time to time or released by an order issued by the Director under section 134 of the Act upon request and submission of such supporting documentation as required by the Director.
- 5.4 Subsection 186(3) of the Act provides that failure to comply with the requirements of the CPU constitutes an offence.
- 5.5 The requirements of the CPU are minimum requirements only and do not relieve the Owner(s) from complying with any other applicable order, statute, regulation,

municipal, provincial or federal law, or obtaining any approvals or consents not specified in the CPU.

- 5.6 Notwithstanding the issuance of the CPU, further requirements may be imposed in accordance with legislation as circumstances require.
- 5.7 In the event that, any person is, in the opinion of the Director, rendered unable to comply with any requirements in the CPU because of,
- a) natural phenomena of an inevitable or irresistible nature, or insurrections,
 - b) strikes, lockouts or other labour disturbances,
 - c) inability to obtain materials or equipment for reasons beyond your control, or
 - d) any other cause whether similar to or different from the foregoing beyond your control,

the requirements shall be adjusted in a manner defined by the Director. To obtain such an adjustment, the Director must be notified immediately of any of the above occurrences, providing details that demonstrate that no practical alternatives are feasible in order to meet the requirements in question.

- 5.8 Failure to comply with a requirement of the CPU by the date specified does not relieve the Owner(s) from compliance with the requirement. The obligation to complete the requirement shall continue each day thereafter.
- 5.9 In the event that the Owner complies with provisions of Items 4.6 and 4.7 of the CPU regarding the registration of the certificate of requirement on title to the Property, and then creates a condominium corporation by the registration of a declaration and description with respect to the Property pursuant to the *Condominium Act*, 1998, S.O. 1998, c.19 and then transfers ownership of the Property to various condominium unit owners, the ongoing obligations of the Owner under this CPU may be carried out and satisfied by the condominium corporation by and on behalf of the new Owners of the Property.

Part 6: Hearing before the Environmental Review Tribunal

- 6.1 Pursuant to section 139 of the Act, you may require a hearing before the Environmental Review Tribunal (the "Tribunal"), if within fifteen (15) days after service on you of a copy of the CPU, you serve written notice upon the Director and the Tribunal.
- 6.2 Pursuant to section 142 of the Act, the notice requiring the hearing must include a statement of the portions of the CPU and the grounds on which you intend to rely at the hearing. Except by leave of the Tribunal, you are not entitled to appeal a portion of the CPU or to rely on a ground that is not stated in the notice requiring the hearing.

- 6.3 Service of a notice requiring a hearing must be carried out in a manner set out in section 182 of the Act and Ontario Regulation 227/07: Service of Documents, made under the Act. The address, email address and fax numbers of the Director and the Tribunal are:

The Secretary
Environmental Review Tribunal
655 Bay Street, Suite 1500
Toronto, ON, M5G 1E5

Fax: (416) 326-5370
Fax Toll Free: 1(844) 213-3474
Email: ERTTribunalSecretary@ontario.ca

and

Paul Widmeyer
Director
119 King Street West, 9th Floor
Hamilton, Ontario
L8P 4Y7

Fax: (905) 521-7806
Email: Paul.Widmeyer@ontario.ca

- 6.4 Unless stayed by application to the Tribunal under section 143 of the Act, the CPU is effective from the date of issue.
- 6.5 If you commence an appeal before the Tribunal, under section 47 of the *Environmental Bill of Rights, 1993* (the “EBR”), you must give notice to the public in the Environmental Registry of Ontario. The notice must include a brief description of the CPU (sufficient to identify it) and a brief description of the grounds of appeal.

The notice must be delivered to the Minister of the Environment, Conservation and Parks who will place it on the Environmental Registry of Ontario. The notice must be delivered to the Minister of the Environment, Conservation and Parks at 777 Bay Street, 5th Floor, Toronto, Ontario M7A 2J3 by the earlier of:

- 6.5.1 two (2) days after the day on which the appeal before the Tribunal was commenced; and
- 6.5.2 fifteen (15) days after service on you of a copy of the CPU.

- 6.6 Pursuant to subsection 47(7) of the EBR, the Tribunal may permit any person to participate in the appeal, as a party or otherwise, in order to provide fair and adequate representation of the private and public interests, including governmental interests, involved in the appeal.
- 6.7 For your information, under section 38 of the EBR, any person resident in Ontario with an interest in the CPU may seek leave to appeal the CPU. Under section 40 of the EBR, the application for leave to appeal must be made to the Tribunal by the earlier of:
- 6.7.1 fifteen (15) days after the day on which notice of the issuance of the CPU is given in the Environmental Registry of Ontario; and
 - 6.7.2 if you appeal, fifteen (15) days after the day on which your notice of appeal is given in the Environmental Registry of Ontario.

Further information on the requirements of the Tribunal regarding an appeal can be obtained directly from the Tribunal at:

Tel: (416) 212-6349

Fax: (416) 326-5370

www.ert.gov.on.ca

Issued at Hamilton this 10th day of July 2020.

Original signed by

Paul Widmeyer
Director, section 168.6 of the Act

Schedule A: Figure 1 – Site Plan (not to scale)

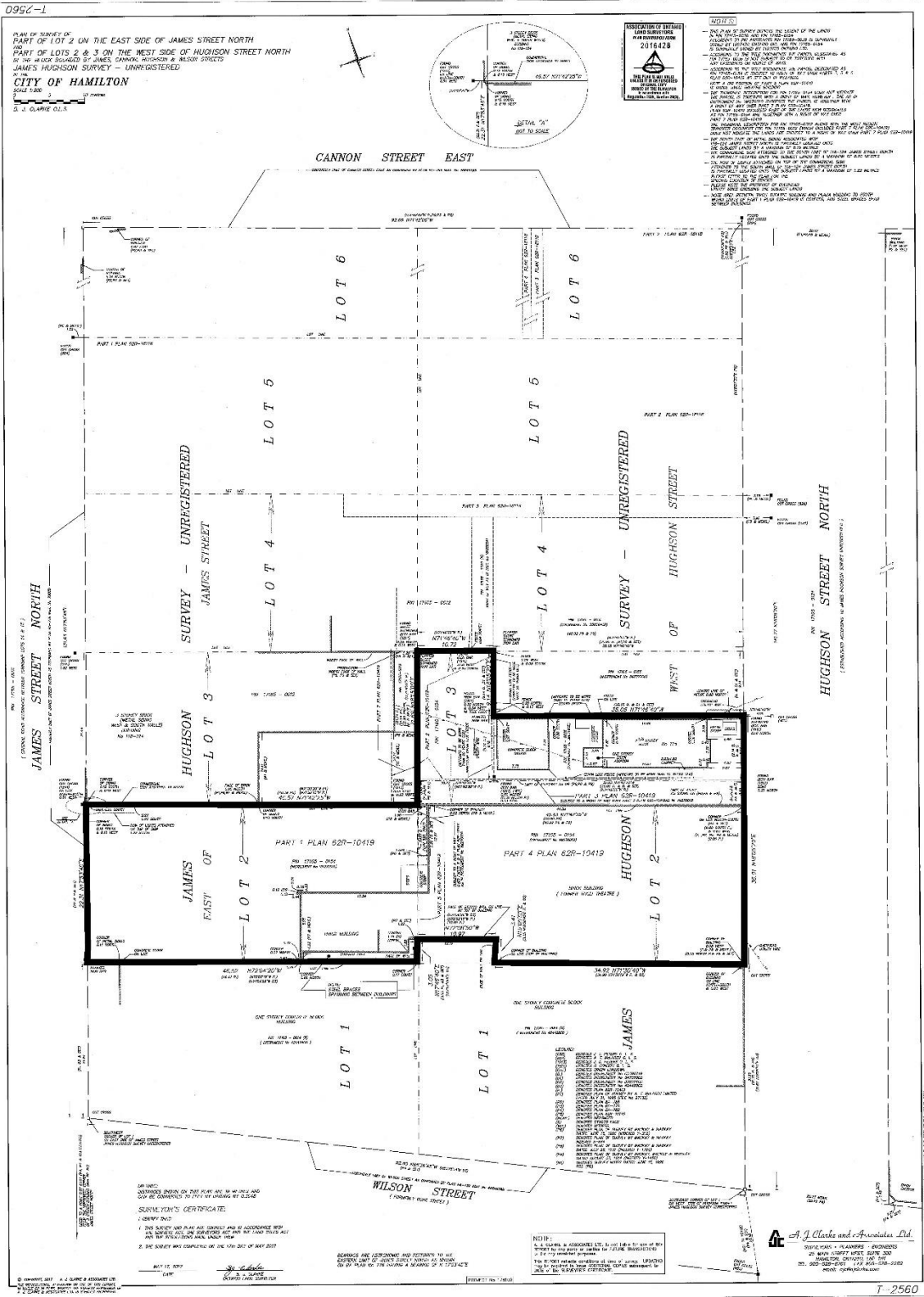

15

Schedule A: Figure 2 – Fill Cap and Hard Cap Conceptual Drawing (not to scale)

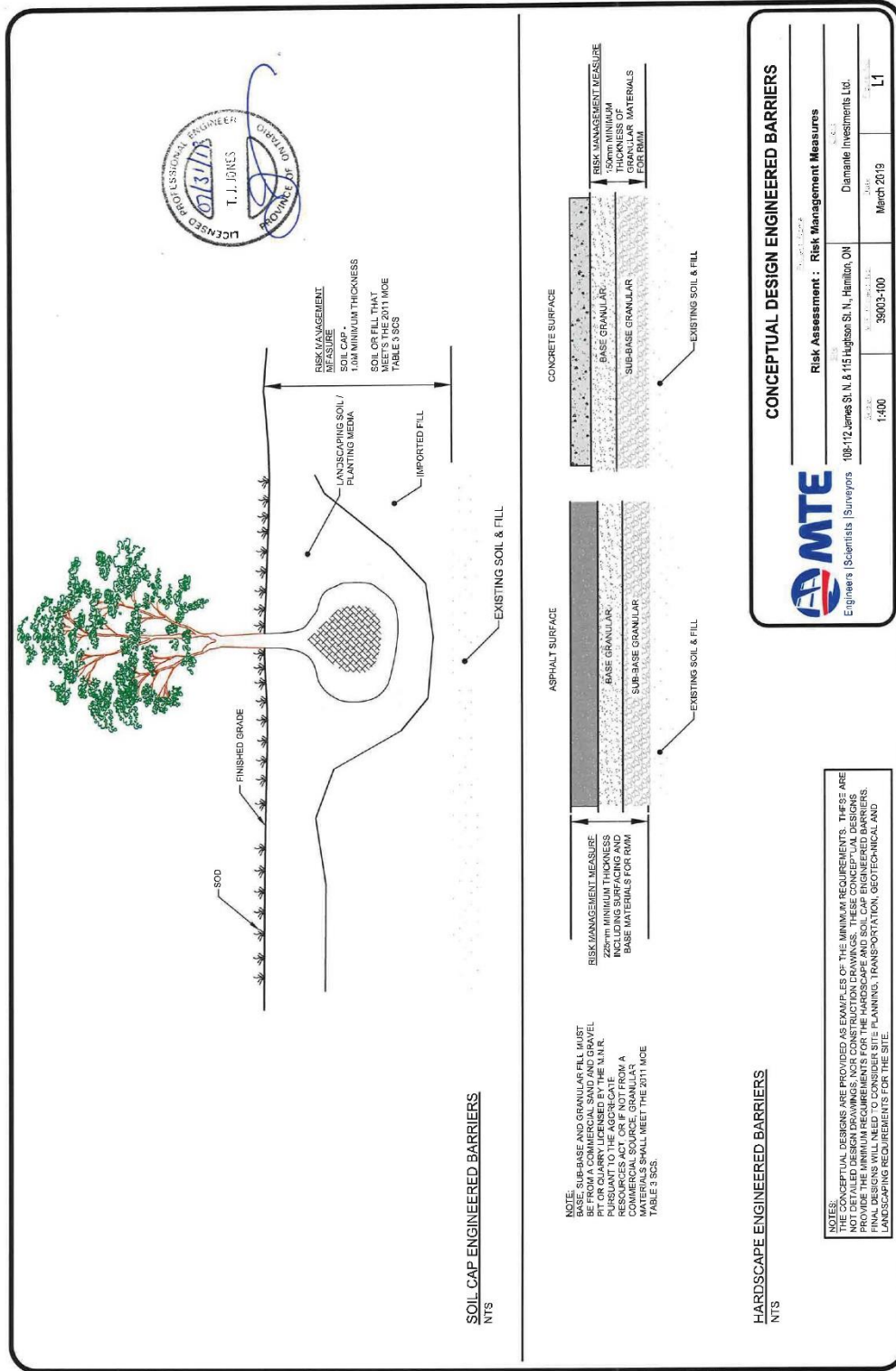

Schedule A: Figure 3 – Root Ball Conceptual Drawing (not to scale)

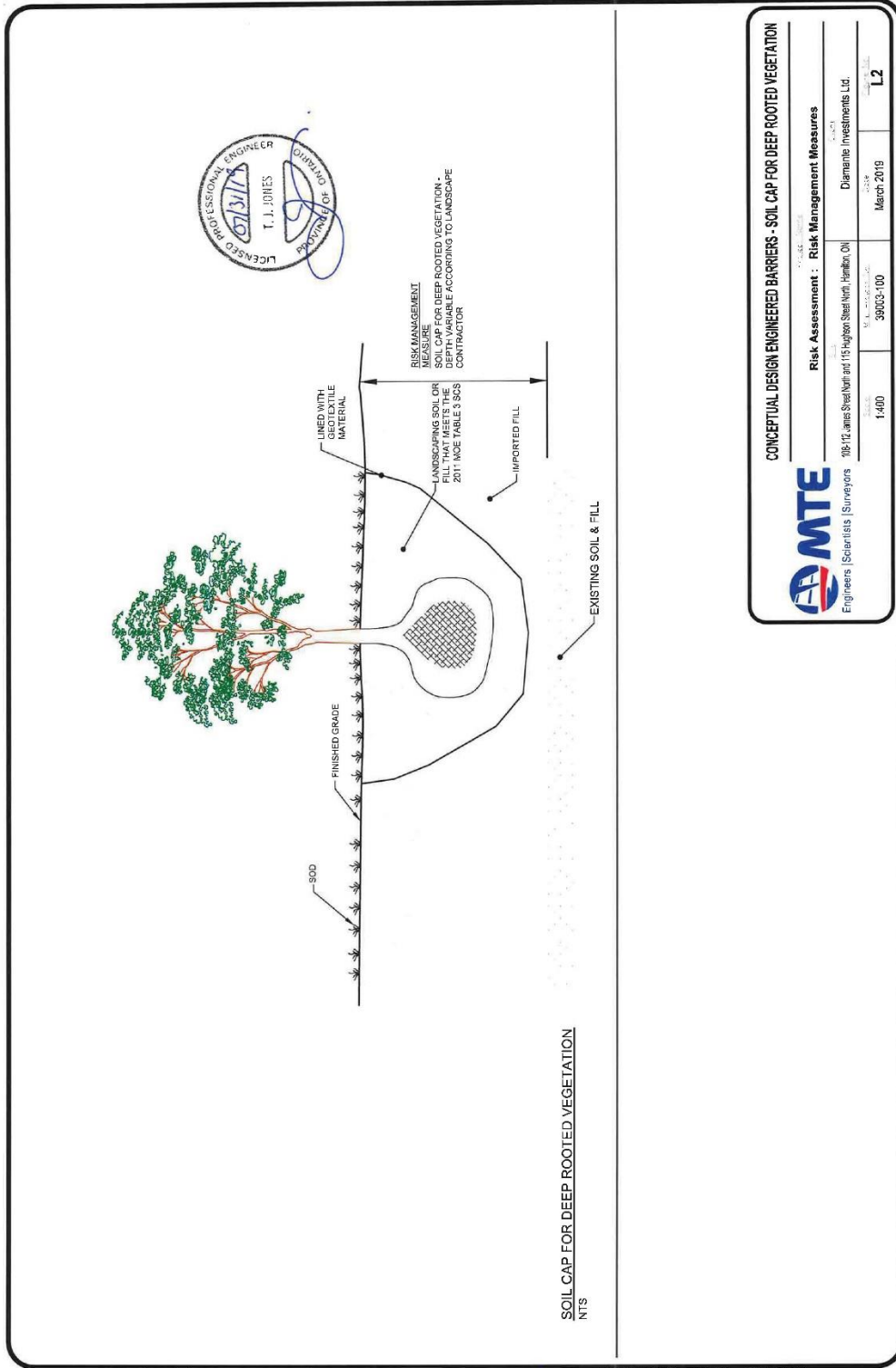

CONCEPTUAL DESIGN ENGINEERED BARRIERS - SOIL CAP FOR DEEP ROOTED VEGETATION

MTE Engineers Scientists Surveyors		Risk Assessment : Risk Management Measures	
188-17 James Street North and 115 Highway 7 East North, Hamilton, ON		Diamante Investments Ltd.	
1:400	39003-100	March 2019	L2

Schedule A: Figure 4 – Soil and Sub-Slab Vapour Monitoring Locations (not to scale)

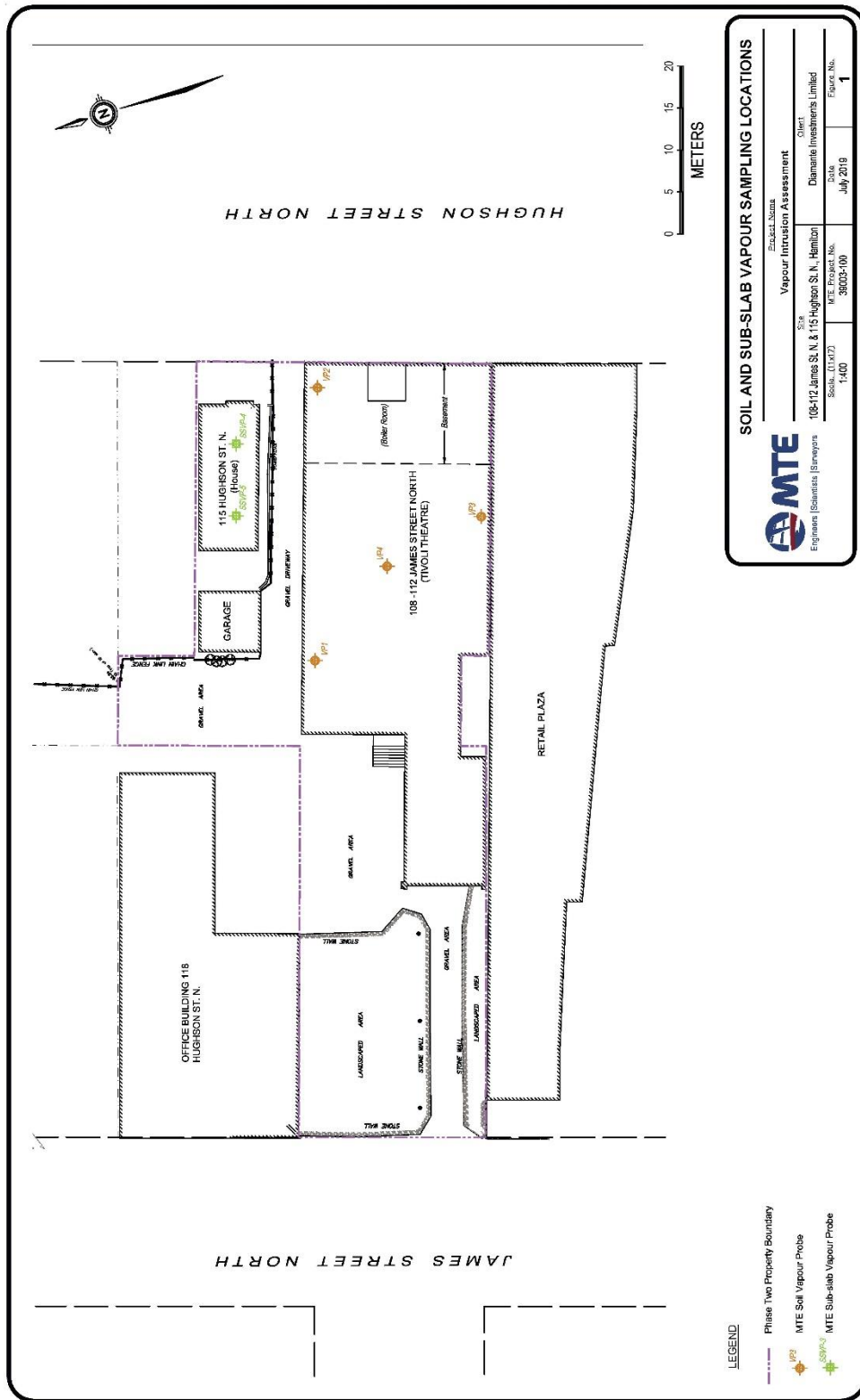

Schedule A: Figure 5 – Utility Dam Conceptual Drawing (not to scale)

March 11, 2018 -- 4:50 p.m. -- Plotted by: imadsen EV1.3 Project: 39003-100 CAD: P:\P\39003\39003-100-EVI.DWG

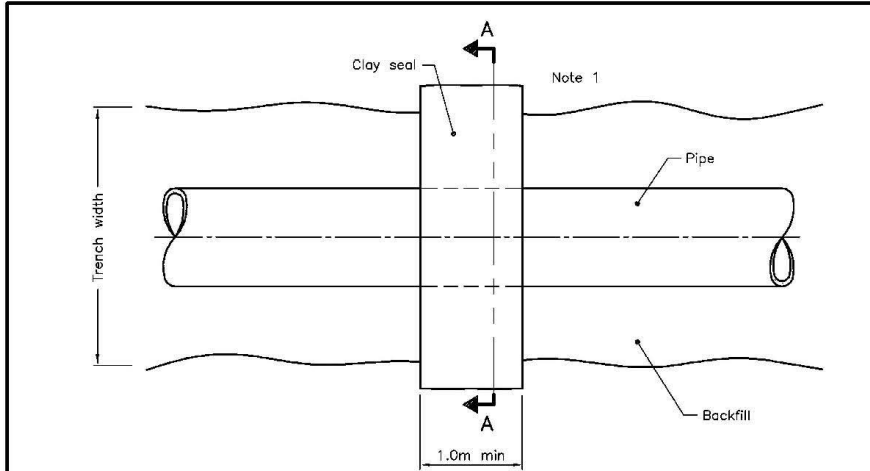

PLAN

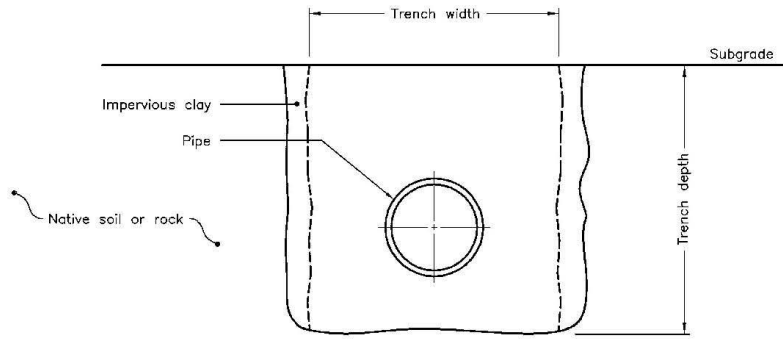

SECTION A-A

NOTES:

- 1. Key into undisturbed trench soil.
- A Clay seal shall extend from bottom of trench excavation to the subgrade.
- B Clay seal shall be located so that no pipe joints are within the clay seal material.
- C All dimensions are in metres unless otherwise shown.

ONTARIO PROVINCIAL STANDARD DRAWING	Nov 2016	Rev 2	
CLAY SEAL FOR PIPE TRENCHES			
OPSD 802.095			

UTILITY DAM			
 <p>MTE Engineers Scientists Surveyors</p>	<small>Project Name</small> Risk Assessment : Risk Management Measures		
	<small>Site</small> 108-112 James St. N. & 115 Hughson St. N., Hamilton, ON		<small>Client</small> Diamante Investments Ltd.
<small>Scale (1:1x17)</small> NTS	<small>MTE Project No.</small> 39003-100	<small>Date</small> March 2019	<small>Figure No.</small> L3

Schedule A: Table 1A: Property Specific Standards – Soil

All values in micrograms per gram except where indicated

Contaminant of Concern	Property-Specific Standard
Boron (Hot Water Soluble)	2.34
Copper	706
Lead	449
Zinc	636
Mercury	3.4
Electrical Conductivity in milli-Siemens per centimetre	1.27
Acenaphthylene	0.19
Anthracene	1.4
Benz[a]anthracene	5.2
Benzo[a]pyrene	2.4
Benzo[b]fluoranthene	2.4
Benzo[k]fluoranthene	1.4
Fluoranthene	6.7
Indeno[1 2 3-cd]pyrene	1.6

Schedule A: Table 1B: Property Specific Standards – Groundwater

All values in micrograms per litre except where indicated

<i>Contaminant of Concern</i>	<i>Property-Specific Standard</i>
Dichloroethylene, 1,2-cis-	12
Tetrachloroethylene	52
Trichloroethylene	17
Vinyl Chloride	19

Schedule A: Table 1C – Soil and Sub-Slab Vapour Criteria

All values in micrograms per cubic metre except where indicated

Contaminant of Concern	Concentration
Tetrachloroethylene	214
Trichloroethylene	13.6
Vinyl Chloride	6.32

Schedule B

CERTIFICATE OF REQUIREMENT

s.197(2)

Environmental Protection Act

This is to certify that pursuant to **Item 4.5** of Certificate of Property Use number **8452-BHMMZD** issued by **Paul Widmeyer**, Director of the Ministry of the Environment, Conservation and Parks, under sections 168.6 and 197 of the *Environmental Protection Act*, on **July 10, 2020**, being a Certificate of Property Use and order under subsection 197(1) of the *Environmental Protection Act* relating to the property municipally known as **108–112 James Street North and 115 Hughson Street North, Hamilton** being all of Property Identifier Number **17165-0291 (LT)** (the “Property”) with respect to a Risk Assessment and certain Risk Management Measures and other preventive measure requirements on the Property

1150735 Ontario Ltd.

and any other persons having an interest in the Property, are required before dealing with the Property in any way, to give a copy of the Certificate of Property Use, including any amendments thereto, to every person who will acquire an interest in the Property.

Under subsection 197(3) of the *Environmental Protection Act*, the requirement applies to each person who, subsequent to the registration of this certificate, acquires an interest in the Property.